



Fahrwerke · Zubehör *Stoßdämpfer*



**WARRANTY INFORMATION** 4**PART SELECTION** 6**KIT SELECTION** 7**SHOCK ABSORBERS** 8**FORD**

COURIER & RANGER.....	10
RANGER 3/2006 ON.....	11

HOLDEN / ISUZU

RODEO	12
KB/TF 4X4, 1981-1988	12
KB/TFS 4X4, 1988-3/2003	13
RA / RA7 / COLORADO / DMAX	14
JACKAROO.....	15
UBS 13, 16, 52, PRE 1986	15
UBS 16, 17, 52, 55, 11/1986-1991.....	16
UBS 25, 69, 4/1992 ON	17
FRONTERA	18

HYUNDAI

TERRACAN	19
----------------	----

JEEP

CHEROKEE.....	20
XJ	20
LIBERTY KJ.....	24
WRANGLER.....	21
GRAND CHEROKEE.....	22
ZJ, ZG.....	22
WJ, WG.....	23

KIA

SORENTO	25
---------------	----

LADA

NIVA.....	25
-----------	----

LANDROVER

DEFENDER	26
90 SERIES.....	26
110 TRAYBACK.....	27
110 COUNTY WAGON	28
RANGEROVER 1971-1995	29
DISCOVERY.....	29
SERIES 1, 1989-1998.....	29
SERIES 2, TD5, 1999-2005	30

MAZDA

BRAVO & RAIDER.....	31
TRIBUTE	32

MITSUBISHI

TRITON	33
ME, MF, MG, MH, MJ, 1993-1996	33
MK, 1996-2006	34
ML, 8/2005 ON	35
PAJERO	36
L200, NA - NG, 1983-1992	36
L200, NH - NL, 1992-1996	37
NF, NG SWB & LWB, 1988-5/1991	38
NH - NL SWB & LWB, 6/1991-2000	39
NM, NP, NS, NT 2000 ON	40
CHALLENGER.....	41
PA, LEAF SPRING REAR	41
PA, COIL SPRING REAR.....	42
DELICA L400	43

NISSAN

PATROL	44
MQ G160, PRE 1984	44
MK G160, 1984-1988	45
GQ Y60 SWB WAGON, 1988-1998	46
GQ Y60 LWB WAGON, 1988-1998.....	47
GQ Y60 CAB CHASSIS AND UTE, 1988 ON....	48
GU Y61 WAGON, 1997 ON	49
GU Y61 CAB CHASSIS AND UTE, 1997 ON....	50
GU Y61 CAB CHASSIS AND UTE, 1997 ON....	51



PATHFINDER & TERRANO.....**52**
 WD21, R20, 1987-1995**52**
 R50, 1995 ON**53**
 R51, 2005 ON**54**

NAVARA.....**55**
 D21, 1985-1996**55**
 D22, 1997-2005**56**
 D40, 2005 ON**57**

XTRAIL.....**58**

SSANGYONG

MUSSO**59**

SUZUKI

SIERRA**60**
 LJ, SJ, 1981 ON**60**
 SJ80, 1997 ON**61**

VITARA.....**62**

GRAND VITARA.....**63**

GRAND VITARA 05 ON.....**64**

SUBARU

FORESTER**65**

TOYOTA

HILUX.....**66**
 LN/RN 36,46, 1979-10/1983**66**
 LN/RN 65,67,105,106, 11/1983-11/1997**67**
 4RUNNER, LN61, YN63, 1988-1997.....**68**
 4RUNNER, VZN/RZN 180/185.....**90**
 SURF / LN/RN/YN/VZN 130 V6, 1988-1997**69**
 LN/RN 106,107,108,110,111,167, SR5, 10/1997-3/2005 .**70**

HILUX / VIGO**71**
 GGN25R KUN26R, 3/2005 ON**71**

LANDCRUISER**72**
 40 SERIES, 1960-1980**72**
 40, 42, 46 SERIES, 1980-1984**73**
 45 SERIES, PRE 7/1980**74**
 45, 47 SERIES, 8/1980-1985.....**75**
 60, 61 SERIES, PRE 1986.....**76**
 60, 61, 62 SERIES, 1986 ON.....**77**

HZJ, PZJ 70, 73, BJ FJ 70, 73, 74, 1984-1993 .. **78**
 BUNDERA LJ RJ 70, 73 75, 1984-1989 **79**
 KZJ 70, 73, 1990-1996 **80**
 71 SERIES.....**81**
 75 SERIES, 1984-1999**82**
 76 SERIES WAGON, 2007 ON.....**83**
 78 SERIES TROOP CARRIER, 1999 ON.....**84**
 79 SERIES TRAYBACK, 1999 ON**85**
 80 SERIES / 105 SERIES WAGON, 1990 ON ... **86**
 100 SERIES WAGON, PETROL, 3/1998 ON ... **87**
 100 SERIES WAGON, DIESEL, 3/1998 ON **88**
 200 SERIES WAGON **89**

PRADO.....**90**
 90 / 95 SERIES, 1996-10/2002 **90**
 120 SERIES, 4/2003 ON **91**

FJ CRUISER**92**

FORTUNER 11/2004 ON.....**93**

COMPETITION - EXTRA LONG TRAVEL

PATROL
 GQ Y60 / GU Y61, 1988 ON **94**

TOYOTA
 80 SERIES / 105 SERIES WAGON, 1990 ON ... **95**

SPECIFICATIONS

COIL SPRINGS**96**

LEAF SPRINGS.....**98**

TORSION BARS**100**

U-BOLTS**101**

COIL SPRING SPACERS**101**

SHOCK ABSORBER BOOTS**101**

GAS SHOCK ABSORBERS**102**

FOAM CELL SHOCK ABSORBERS.....**104**

STEERING DAMPERS**105**

MOUNT CODES**106**

LOAD PLUS **107**

TERMS & CONDITIONS **108**

WARRANTY INFORMATION



Ironman 4x4 warrants the original buyer, only when purchased new via authorised Ironman 4x4 resellers and distributors, from date of retail sale.

Product is warranted against defects in material or workmanship that cause the product to perform below the specified limits set by Ironman 4x4, to the extent that Ironman 4x4 will repair or replace any parts which are found to be defective.

All warranty claims must be submitted via original purchasing store or chain, unless otherwise arranged.

Proof of original purchase must be presented upon request.

Products may require to be returned to Ironman 4x4 for assessment or repair. Postage and removal costs involved are not the responsibility of Ironman 4x4, and may only be considered upon discretion by Ironman 4x4 in the event of such claim being verified.

The warranty does NOT apply where, 1) acts of neglect or misuse are evident, 2) product has been modified, 3) vehicles which are modified or not the recommended vehicle of use, 4) used in racing or competition conditions without the prior consent of Ironman 4x4, 5) used beyond the expectations of the original vehicle manufacturer.

Before installation of any product, please ensure you have received the correct parts for your application.

Ordering of the correct parts is the responsibility of the buyer. Return of a product in an un-used condition will attract a 15% restock fee, where Ironman 4x4 is not at fault.

Return of used or soiled product, 1) outside warranty period, 2) without fault, will result in refusal of your claim and be returned at buyer's expense.

SUSPENSION:

All suspension products must undergo safety check at 500km after fitment. Fitment should be performed by an authorised or licensed mechanic, competent with suspension installations.

Special tools may be required when fitting some parts including struts. Damage to products through fitment error is not covered under warranty.

Warranty may become void when product is installed in conjunction with anything other than genuine manufacturer or Ironman components.

Where required, Ironman 4x4 recommend wheel alignment after fitment of any new suspension component. Obtaining wheel alignments is the responsibility of the buyer.

FREIGHT CONDITIONS:

Freight of all products is the buyer's responsibility.

Where Ironman 4x4 have arranged freight, costs involved will be invoiced to the buyer.

Ironman 4x4 is not responsible for damage or loss during freight.

FITTING:

All prices listed may be subject to fitting costs. The price of fitting is determined by the individual fitting agent.



NOTES

NOTES

PART SELECTION



Choosing The Right Spring

Leaf Springs: Part number suffix A. (eg. TOY057A)

Will provide some lift from standard and used where comfort is preferred rather than firm control. This design is best suited to light or no load applications.

Coil and Leaf Springs: Part number suffix B. (eg. TOY025B)

Ride will be firmer than original by around 20% and suits light to medium loads. This spring is recommended when the given load may be occasional or temporary. Excellent for vehicles which have some accessories fitted.

Coil and Leaf Springs: Part number suffix C. (eg. TOY025C)

Will provide excellent support for vehicle's carrying constant heavy loads. Suitable when multiple heavy accessories or steel tray's / toolboxes fitted. These springs should be avoided when vehicle has light or no load present.

Leaf Springs: Part number suffix D. (eg. TOY009D)

Extra heavy duty springs designed to support heavier constant loads when heavy accessories are combined with heavy payloads

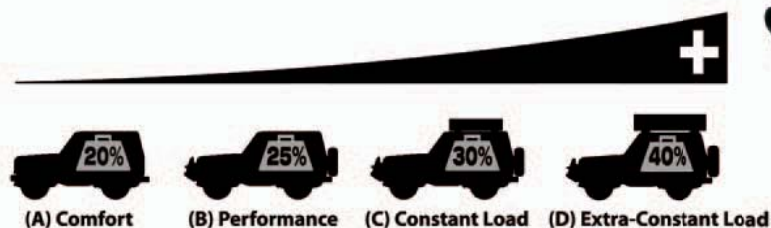

Choosing The Right Shock Absorber

Nitro Gas: Part number suffix GR.

Twin Tube 35mm Bore and Piston.

These shock absorbers are best suited to medium and heavy loads. Vehicle will become firmer and more responsive. Will provide excellent resistance to body roll when cornering.

Nitro Gas Soft Ride: Part number suffix GRC.

Twin Tube 35mm Bore and Piston

These shock absorbers are available for selected vehicle's where comfort is preferred rather than firm control. The softer valving is best suited to light or no load applications.

Foam Cell: Part number suffix FE.

Twin Tube 41mm Bore and Piston.

These shock absorbers provide similar benefits to the Nitro Gas GR shock absorber. The Foam Cell shock absorber features larger piston and bore size to allow for more oil capacity which allows the shock absorber to operate cooler in rough offroad conditions or long haul corrugations





How Much Lift Will I Get?

All Coil and Leaf Springs are accompanied by a suggested weight range throughout this catalogue.

This suggestion is provided as an assistance to spring selection and is not indicative of the springs full ability.

The stated lift for each vehicle is relative to the suggested weight loading and is based upon the minimum value of this suggested weight loading.

The lift heights quoted are a general figure only, calculated as an average of both Front and Rear, and are relative to new vehicle ride heights. The position of added weight can also affect the outcome.

Which Kit Do I Choose?

The correct selection of a suspension kit is vital to a successful outcome.

Each vehicle should be treated as an individual case, as many variables can affect the final result.

When assessing a vehicle and choosing a kit, the following must be noted:

- *Engine type, Petrol, Diesel, Turbo Diesel? Perhaps an engine conversion which is heavier than the original?*
- *Added accessories such as bull bar, winch, second battery, extra spare wheel, drawer system, roof rack, steel tray, sub tanks etc. can all alter the outcome.*
- *Take note the location of these accessories as the re-location can also disrupt the weight balance.*
- *Carefully note the production date and series of the vehicle as many parts may differ from model to model.*
- *Understand the usage of the vehicle, such as how and where the vehicle will be driven. - eg. different terrains and speeds.*

The Ironman suspension kit part numbering system is constructed as follows:

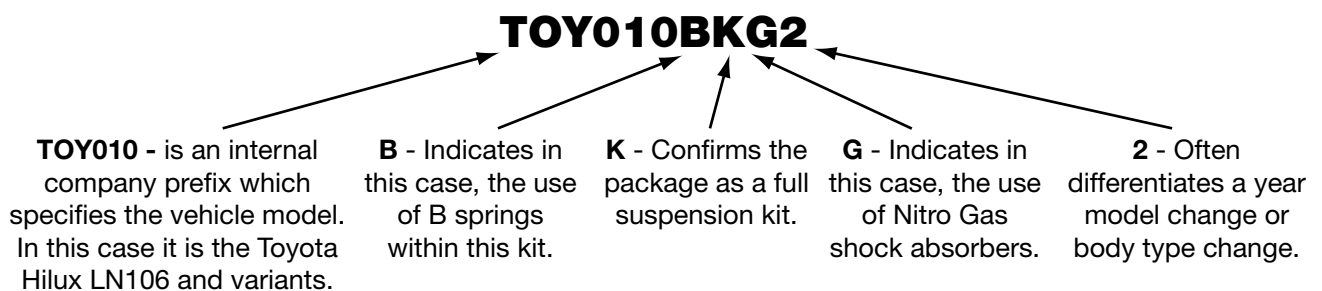

Customising The Kit

Generally, as no two vehicles are alike, customizing a suspension kit is recommended and can be discussed with the Ironman team.

For example:

A listed suspension kit, eg. TOY010BKG2 will have B springs supplied front and rear by default. This may not be suitable for a vehicle that carries heavy load in the rear only. In this case we would suggest C rear springs but front will remain the B.

Kit customisation is relevant when selecting springs and shock absorbers only. This service is only available upon request.

4x4 SHOCK ABSORBER RANGE



Year	Vehicle Description	Nitro Gas		Foam Cell		Steering Damper
		Front	Rear	Front	Rear	
FORD						
Pre 8/1989	Maverick Hardtop SWB, LWB	12091GR	12094GR	24091FE	24094FE	3534
9/1989 On	Maverick Hardtop SWB, LWB	12091GR	12094GR	24091FE	24094FE	3536
All	Maverick Cab Chassis & Ute	12661GR	12648GR	24661FE	24648FE	3522
1988 On	Courier / Ranger 4X4	12667GR	12095GR	24667FE	24095FE	
HOLDEN / ISUZU						
1985-1987	Drover QB	12085GR	12086GR			3530
1982-10/1986	Jackaroo UBS 13, 16, 52	12087GR	12636GR ^(C)	24087FE	24636FE	
11/1986-3/1992	Jackaroo UBS 16, 17, 52	12087GR	12671GR	24087FE		
4/1992-2003	Jackaroo UBS 25 & 69	12643GR	12644GR	24643FE	24644FE	
Pre 7/1988	Rodeo KB/TF 4X4	12087GR	12636GR ^(C)	24087FE	24636FE	
7/1988 On	Rodeo KB/TFS 4X4	12643GR	12636GR ^(C)	24643FE		
3/2003 On	Rodeo RA / RA7 / Colorado / DMax	12667GR	12636GR ^(C)	24667FE	24636FE	
10/1995-1/1999	Frontera	12667GR	12644GR	24667FE	24644FE	
HYUNDAI						
2001 On	Terracan	12087GR	12637GR ^(C)	24087FE		
JEEP						
4/1994 On	Cherokee Classic XJ	12665GR	12666GR	24665FE	24666FE	3540
3/1996-1998	Grand Cherokee ZG, ZJ	12665GR	12670GR	24665FE		3540
10/1996 On	Wrangler TJ	12665GR	12669GR	24665FE		3540
1999 6/2005	Grand Cherokee WJ/WG	12774GR	12775GR			3540
2002 On	KJ Liberty, Sport & Limited	12711GR	12712GR			
LAND ROVER						
11/1984 On	Defender, 90, 110, County Wagon, Trayback	12080GR	12640GR	24080FE	24640FE	3532
1974-1995	Range Rover (Without Air Suspension)	12080GR	12640GR	24080FE	24640FE	3511
1989-1998	Discovery Series I	12080GR	12640GR	24080FE	24640FE	3511
1999 On	Discovery Series II, Td5	12776GR	12777GR	24776FE	24777FE	3502
MAZDA						
1988 On	Bravo / Raider 4x4 / BT50	12667GR	12095GR	24667FE	24095FE	
MITSUBISHI						
1983-4/1991	Pajero / Montero L200 (Leaf)	12082GR	12636GR ^(C)	24082FE	24636FE	3517 ⁽¹⁾
1991-3/2000	Pajero / Montero L200 (Leaf)	12087GR	12636GR ^(C)	24087FE	24636FE	
1988-4/1991	Pajero / Montero NF,NG,NH & NJ (Coils)	12082GR	12645GR	24082FE	24645FE	3517 ⁽¹⁾
5/1991-2000	Pajero / Montero NF,NG,NH & NJ (Coils)	12087GR	12646GR	24087FE	24646FE	
4/2000 On	Pajero / Montero NM,NP,NS,NT	12713GR	12714GR			
1998 On	Challenger / Montero Sport (Leaf)	12087GR	12636GR ^(C)	24087FE	24636FE	
1998 On	Challenger / Montero Sport (Coils)	12087GR	12645GR	24087FE	24645FE	
1983-8/1996	Triton / Strada ME,MF,MG,MH,MJ	12082GR	12698GR ^(C)	24082FE	24698FE	
9/1996-7/2005	Triton / Strada MK	12087GR	12698GR ^(C)	24087FE	24698FE	
8/2005 On	Triton ML / L200 (Coil Springs Front)	12715GR	12636GR ^(C)			
5/1994-2001	L400 Delica LWB (Without ECS) ⁽²⁾	12667GR	12698GR ^(C)	24667FE		
5/1994-2001	L400 Delica LWB (With ECS) ⁽²⁾	12667GR	12671GR	24667FE		

NOTES:

- (C) Comfort Shock Absorbers Available (12xxxGRC).
 (0) (12661GR) (24661FE) Must order Part # 895 Tube to Convert Lower Eye.
 (1) (3517) Fits Non Power Steering Models only.
 (2) (ECS) Electronic Control Suspension.
 (3) (12650GR & 24650FE) Bundera Right Side.
 (4) (12639GR & 24639FE) Bundera Left Side
 (5) (12639GR & 24639FE) Must order Part # 630 to convert lower eye to 19mm.



4x4 SHOCK ABSORBER RANGE

Year	Vehicle Description	Nitro Gas		Foam Cell		Steering Damper
		Front	Rear	Front	Rear	
NISSAN						
1961-1988	Patrol G60 SWB & MWB	12075GR	12075GR			3522
9/1980-1988	Patrol MQ/MK G160	12075GR	12076GR			3522
2/1988 On	Patrol GQ/GR Y60 Cab Chassis (Leaf Springs)	12661GR	12648GR	24661FE	24648FE	3522
2/1988-8/1989	Patrol GQ/GR Y60 Station Wagon	12091GR	12094GR	24091FE	24094FE	3534
8/1989 On	Patrol GQ/GR Y60 Station Wagon	12091GR	12094GR	24091FE	24094FE	3536
9/1991-5/1999	Patrol GQ Y60 Cab Chassis (Coil Springs)	12091GR	12094GR	24091FE	24094FE	3536
1989 On	Patrol Y260 2.8TD	12080GR	12636GR ^c	24080FE	24636FE	3522
Pre 2/2000	Patrol GU Y61 Wagon & Ute (Series I)	12091GR	12094GR	24091FE	24094FE	3511
2/2000 On	Patrol GU Y61 Wagon & Ute (Series II,III)	12091GR	12094GR	24091FE	24094FE	3501
1997 On	Patrol GU Y61 Cab Chassis (Leaf Springs Rear)	12091GR	12648GR	24091FE	24648FE	3511
1986-3/1997	Navara D21	12087GR	12636GR ^c	24087FE	24636FE	3535
4/1997 On	Navara D22	12791GR	12636GR ^c		24636FE	
2005 On	Navara D40	12716GR	12717GR			
1997 On	Terrano R20	12667GR	12636GR ^c	24667FE	24636FE	
1986-8/1995	Pathfinder WD21	12667GR	12636GR ^c	24667FE	24636FE	3535
7/2005 On	Pathfinder R51	12716GR	12718GR			
SSANGYONG						
7/1996 On	Musso	12667GR	12661GR ^o	24667FE	24661FE ^o	
SUZUKI						
1974 On	Sierra LJ/SJ (Leaf Springs)	12085GR	12086GR			3530
7/1988-1998	Vitara 3 Door SWB	12083GR	12089GR			
4/1988-7/2005	Vitara 5 Door LWB / XL7 / Grand Vitara	12083GR	12658GR			
8/2005 On	Grand Vitara	12721GR	12722GR			
TOYOTA						
4/1979-10/1983	Hilux LN65,YN65,67 (Live Axle) (Leaf Springs)	12639GR ^c	12636GR ^c	24639FE	24636FE	3521
11/1983-11/1997	Hilux RN105,LN106 (Live Axle) (Leaf Springs)	12639GR ^c	12650GR ^c	24639FE	24650FE	3521
11/1989-1997	4 Runner/Surf LN,VZN130,YN (IFS)(Coil Springs)	12088GR	12637GR ^c	24088FE	24637FE	3533
1988-9/1997	Hilux LN/YN110,LN111,SR5 (IFS) (Leaf Springs)	12088GR	12650GR ^c	24088FE	24650FE	3533
10/1997-3/2005	Hilux Extra Cab RN106,LN107/108,167,SR5	12088GR	12081GR ^c	24088FE	24081FE	3533
3/2005 On	Hilux GGN25R, KUN26R, Cab Chassis & Ute	12710GR	12650GR ^c			
1980 On	Landcruiser BJ/FJ/HJ40,42,45,46,47	12635GR ^c	12636GR ^c	24635FE	24636FE	3523
Pre 1986	Landcruiser FJ/HJ60/61/62	12637GR ^c	12636GR ^c	24637FE	24636FE	3524
8/1986-3/1990	Landcruiser FJ-HJ60/61/62	12637GR ^c	12650GR ^c	24637FE	24650FE	3524
11/1984-1989	Landcruiser LJ70,73, Bundera (Coil Springs)	12091GR	12650GR ³	24091FE	24650FE ³	3524
			12639GR ^{4,5}		24639FE ^{4,5}	
8/1980 On	Landcruiser BJ70,73,74 FJ70-73,77	12637GR ^c	12650GR ^c	24637FE	24650FE	3524
1990-1996	Landcruiser KZJ70,73,77	12696GR	12697GR	24696FE	24697FE	3524
1984 On	Landcruiser FJ-HJ-HZJ75 Ute & Troop Carrier	12637GR ^c	12081GR ^c	24637FE	24081FE	3524
1999-2007	Landcruiser HZJ78,79	12091GR	12094GR	24091FE	24094FE	3524
2007 On	Landcruiser HZJ76/78,79	12091GR	12094GR	24091FE	24094FE	3525
1990 On	Landcruiser FJ/HZJ 80 / 105 (Live Axle)	12683GR	12682GR	24683FE	24682FE	3524
3/1998 On	Landcruiser HDJ/UZJ100 (IFS)	12795GR	12796GR	24795FE	24796FE	
2008 on	Landcruiser 200 Series	12720GR	12796GR		24796GR	
7/1996-10/2002	Prado 90,95 Series	12691GR	12661GR		24661FE	
4/2003 On	Prado 120 / FJ Cruiser	12710GR	12682GR		24682FE	
11/2004 On	Fortuner	12710GR	12637GR ^c		24637FE	
COMPETITION - EXTRA LONG TRAVEL						
2/1988 On	Patrol GQ/GR/GU (Coil Springs) Suit 4" Lift			24091LFE	24094LFE	
2/1988 On	Patrol GQ/GR/GU (Coil Springs) Suit 6" Lift			24091LFE1	24094LFE1	
1990 On	Landcruiser FJ/HZJ 80 / 105 Suit 4" Lift			24683LFE	24682LFE	
1990 On	Landcruiser FJ/HZJ 80 / 105 Suit 6" Lift			24683LFE1	24682LFE1	

COURIER & RANGER

1987 - 2006

40mm Lift



FRONT SUSPENSION

Product	Part Number	Qty Req'd
SHOCK ABSORBER		
Nitro Gas	12667GR	2
Foam Cell	24667FE	2
SPRING		
Uprated Torsion Bar	MAZDA005	1

REAR SUSPENSION

Product	Part Number	Qty Req'd	
SHOCK ABSORBER			
Nitro Gas	12095GR	2	
Foam Cell	24095FE	2	
LEAF SPRING			
	Additional Weight		
Comfort	0-100kg	MAZDA006A	2
Performance	0-200kg	MAZDA006B	2
Constant Load	200-400kg	MAZDA006C	2
Mining	400kg-GVM	MAZDA006D	2
U-BOLTS			
U-Bolt Kit	415UBK	2	
POLYURETHANE SPRING BUSHES			
Complete Set	756UK	1	
GREASABLE SHACKLES & PINS			
Greasable Shackle	386-1	2	
Greasable Pin	794	2	

SUSPENSION KIT

Product	Part Number
Comfort with Gas Shocks	MAZDA006AKG
Comfort with Foam Cell Shocks	MAZDA006AKF
Performance with Gas Shocks	MAZDA006BKG
Performance with Foam Cell Shocks	MAZDA006BKF
Constant Load with Gas Shocks	MAZDA006CKG
Constant Load with Foam Cell Shocks	MAZDA006CKF
Mining with Gas Shocks	MAZDA006DKG
Mining with Foam Cell Shocks	MAZDA006DKF

NOTE: Image above indicates kit contents.



RANGER
3/2006 On
40mm Lift

FRONT SUSPENSION

Product	Part Number	Qty Req'd
SHOCK ABSORBER		
Nitro Gas	12667GR	2
Foam Cell	24667FE	2
SPRING		
Uprated Torsion Bar	MAZDA014	1

REAR SUSPENSION

Product	Part Number	Qty Req'd	
SHOCK ABSORBER			
Nitro Gas	12095GR	2	
Foam Cell	24095FE	2	
LEAF SPRING			
	Additional Weight		
Comfort	0-100kg	MAZDA041A	2
Performance	0-200kg	MAZDA041B	2
Constant Load	200-400kg	MAZDA041C	2
Mining	400kg-GVM	MAZDA041D	2
U-BOLTS			
U-Bolt Kit	417UBK	2	
POLYURETHANE SPRING BUSHES			
Complete Set	759UK	1	
GREASABLE SHACKLES & PINS			
Greasable Shackle	386-1	2	

SUSPENSION KIT

Product	Part Number
Comfort with Gas Shocks	MAZDA041AKG
Comfort with Foam Cell Shocks	MAZDA041AKF
Performance with Gas Shocks	MAZDA041BKG
Performance with Foam Cell Shocks	MAZDA041BKF
Constant Load with Gas Shocks	MAZDA041CKG
Constant Load with Foam Cell Shocks	MAZDA041CKF
Mining Load with Gas Shocks	MAZDA041DKG
Mining Load with Foam Cell Shocks	MAZDA041DKF

NOTE: Image above indicates kit contents.

RODEO
KB/TF 4X4
 1981 - 1988
 40mm Lift



FRONT SUSPENSION

Product	Part Number	Qty Req'd	
SHOCK ABSORBER			
Nitro Gas	12087GR	2	
Foam Cell	24087FE	2	
SPRING			
Up-rated Torsion Bar	1981 - 1983	HOLD003A	1
Up-rated Torsion Bar	1983 - 1988	MAZDA005	1

REAR SUSPENSION

Product	Part Number	Qty Req'd	
SHOCK ABSORBER			
Nitro Gas	<i>Comfort Soft Ride</i>	12636GRC	2
Nitro Gas		12636GR	2
Foam Cell		24636FE	2
LEAF SPRING			
	Additional Weight		
Comfort Drivers Side	0-100kg	HOLD004AD/S	1
Comfort Near Side	0-100kg	HOLD004AN/S	1
Performance Drivers Side	0-300kg	HOLD004BD/S	1
Performance Drivers Side	0-300kg	HOLD004BN/S	1
Constant Load Drivers Side	300kg-GVM	HOLD004CD/S	1
Constant Load Near Side	300kg-GVM	HOLD004CN/S	1

U-BOLTS

U-Bolt Kit	451UBK	2
------------	--------	---

POLYURETHANE SPRING BUSHES

Complete Set	728UK	1
--------------	-------	---

GREASABLE SHACKLES & PINS

Greasable Shackle	791	2
Greasable Pin	792	2

SUSPENSION KIT

Product	Part Number
Comfort with Gas Shocks	HOLD004AKG1
Comfort with Foam Cell Shocks	HOLD004AKF1
Performance with Gas Shocks	HOLD004BKG1
Performance with Foam Cell Shocks	HOLD004BKF1
Constant Load with Gas Shocks	HOLD004CKG1
Constant Load with Foam Cell Shocks	HOLD004CKF1

NOTE: Image above indicates kit contents.



RODEO
KB/TFS 4X4
 1988 - 3/2003
 40mm Lift

FRONT SUSPENSION

Product	Part Number	Qty Req'd
SHOCK ABSORBER		
Nitro Gas	12643GR	2
SPRING		
Uprated Torsion Bar	HOLD005A	1

REAR SUSPENSION

Product	Part Number	Qty Req'd	
SHOCK ABSORBER			
Nitro Gas	<i>Comfort Soft Ride</i>	12636GRC	2
Nitro Gas		12636GR	2
LEAF SPRING			
	Additional Weight		
Comfort Drivers Side	0-100kg	HOLD004AD/S	1
Comfort Near Side	0-100kg	HOLD004AN/S	1
Performance Drivers Side	0-300kg	HOLD004BD/S	1
Performance Drivers Side	0-300kg	HOLD004BN/S	1
Constant Load Drivers Side	300kg-GVM	HOLD004CD/S	1
Constant Load Near Side	300kg-GVM	HOLD004CN/S	1
U-BOLTS			
U-Bolt Kit	415UBK	2	
POLYURETHANE SPRING BUSHES			
Complete Set	728UK	1	
GREASABLE SHACKLES & PINS			
Greasable Shackle	386-2	2	
Non Greasable Pin	387-1	2	

SUSPENSION KIT

Product	Part Number
Comfort with Gas Shocks	HOLD004AKG2
Performance with Gas Shocks	HOLD004BKG2
Constant Load with Gas Shocks	HOLD004CKG2

NOTE: Image above indicates kit contents.

RODEO / COLORADO

RA, RA7, D-MAX

3/2003 On

40mm Lift



FRONT SUSPENSION

Product	Part Number	Qty Req'd
SHOCK ABSORBER		
Nitro Gas	12667GR	2
Foam Cell	24667FE	2
SPRING		
Uprated Torsion Bar	HOLD010	1

REAR SUSPENSION

Product	Part Number	Qty Req'd	
SHOCK ABSORBER			
Nitro Gas	<i>Comfort Soft Ride</i>	12636GRC	2
Nitro Gas		12636GR	2
LEAF SPRING			
	Additional Weight		
Comfort	0-100kg	HOLD006A	2
Performance	0-300kg	HOLD006B	2
Constant Load	300kg-GVM	HOLD006C	2
U-BOLTS			
U-Bolt Kit	417UBK	2	
POLYURETHANE SPRING BUSHES			
Complete Set	728TUK	1	
GREASABLE SHACKLES & PINS			
Greasable Shackle	386-2	2	
Non Greasable Pin	387-1	2	

SUSPENSION KIT

Product	Part Number
Comfort with Gas Shocks	HOLD006AKG
Performance with Gas Shocks	HOLD006BKG
Constant Load with Gas Shocks	HOLD006CKG

NOTE: Image above indicates kit contents.



JACKAROO / TROOPER

UBS 13, 16, 52

Pre 1986

40mm Lift

FRONT SUSPENSION

Product	Part Number	Qty Req'd
SHOCK ABSORBER		
Nitro Gas	12087GR	2
Foam Cell	24087FE	2
SPRING		
Uprated Torsion Bar	MAZDA005	1

REAR SUSPENSION

Product	Part Number	Qty Req'd	
SHOCK ABSORBER			
Nitro Gas	<i>Comfort Soft Ride</i>	12636GRC	2
Nitro Gas		12636GR	2
Foam Cell		24636FE	2
LEAF SPRING			
	Additional Weight		
Comfort Drivers Side	0-100kg	HOLD004AD/S	1
Comfort Near Side	0-100kg	HOLD004AN/S	1
Performance Drivers Side	0-300kg	HOLD004BD/S	1
Performance Drivers Side	0-300kg	HOLD004BN/S	1
Constant Load Drivers Side	300kg-GVM	HOLD004CD/S	1
Constant Load Near Side	300kg-GVM	HOLD004CN/S	1
U-BOLTS			
U-Bolt Kit	451UBK	2	
POLYURETHANE SPRING BUSHES			
Complete Set	747UK	1	
GREASABLE SHACKLES & PINS			
Greasable Shackle	791	2	
Greasable Pin	792	2	

SUSPENSION KIT

Product	Part Number
Comfort with Gas Shocks	HOLD005AKG
Comfort with Foam Cell Shocks	HOLD005AKF
Performance with Gas Shocks	HOLD005BKG
Performance with Foam Cell Shocks	HOLD005BKF
Constant Load with Gas Shocks	HOLD005CKG
Constant Load with Foam Cell Shocks	HOLD005CKF

NOTE: Image above indicates kit contents.

JACKAROO / TROOPER

UBS 16, 17, 52, 55

11/1986 - 1991, Leaf Springs Rear

40mm Lift



FRONT SUSPENSION

Product		Part Number	Qty Req'd
SHOCK ABSORBER			
Nitro Gas		12087GR	2
Foam Cell		24087FE	2
SPRING			
Uprated Torsion Bar	33mm Spine	HOLD005A	1
Uprated Torsion Bar	36mm Spine	HOLD007	1

REAR SUSPENSION

Product		Part Number	Qty Req'd
SHOCK ABSORBER			
Nitro Gas		12671GR	2
LEAF SPRING			
	Additional Weight		
Comfort Drivers Side	0-100kg	HOLD004AD/S	1
Comfort Near Side	0-100kg	HOLD004AN/S	1
Performance Drivers Side	0-300kg	HOLD004BD/S	1
Performance Drivers Side	0-300kg	HOLD004BN/S	1
Constant Load Drivers Side	300kg-GVM	HOLD004CD/S	1
Constant Load Near Side	300kg-GVM	HOLD004CN/S	1
U-BOLTS			
U-Bolt Kit		451UBK	2
POLYURETHANE SPRING BUSHES			
Complete Set		747UK	1
GREASABLE SHACKLES & PINS			
Greasable Shackle		791	2
Greasable Pin		792	2

SUSPENSION KIT

Product	Part Number
Comfort with Gas Shocks	HOLD007AKG
Performance with Gas Shocks	HOLD007BKG
Constant Load with Gas Shocks	HOLD007CKG

NOTE: Image above indicates kit contents.



JACKAROO / TROOPER

UBS 25, 69
4/1992 On
40mm Lift

FRONT SUSPENSION

Product	Part Number	Qty Req'd
SHOCK ABSORBER		
Nitro Gas	12643GR	2
Foam Cell	24643FE	2
SPRING		
Uprated Torsion Bar	HOLD009	1

REAR SUSPENSION

Product	Part Number	Qty Req'd	
SHOCK ABSORBER			
Nitro Gas	12644GR	2	
Foam Cell	24644FE	2	
COIL SPRING			
	Additional Weight		
Performance	0-300kg	HOLD008B	1
Constant load	300kg-GVM	HOLD008C	1

SUSPENSION KIT

Product	Part Number
Performance with Gas Shocks	HOLD008BKG
Performance with Foam Cell Shocks	HOLD008BKF
Constant Load with Gas Shocks	HOLD008CKG
Constant Load with Foam Cell Shocks	HOLD008CKF

NOTE: Image above indicates kit contents.

FRONTERA

1995-1/1999

45mm Lift



FRONT SUSPENSION

Product	Part Number	Qty Req'd
SHOCK ABSORBER		
Nitro Gas	12667GR	2
Foam Cell	24667FE	2
SPRING		
Upated Torsion Bar	HOLD009	1

REAR SUSPENSION

Product	Part Number	Qty Req'd	
SHOCK ABSORBER			
Nitro Gas	12644GR	2	
Foam Cell	24644FE	2	
COIL SPRING			
Performance	0-300kg	HOLD008B	1
Constant load	300kg-GVM	HOLD008C	1

SUSPENSION KIT

Product	Part Number
Performance with Gas Shocks	HOLD008BKG1
Performance with Foam Cell Shocks	HOLD008BKF1
Constant Load with Gas Shocks	HOLD008CKG1
Constant Load with Foam Cell Shocks	HOLD008CKF1

NOTE: Image above indicates kit contents.



TERRACAN

2001 On
40mm Lift

FRONT SUSPENSION

Product	Part Number	Qty Req'd
SHOCK ABSORBER		
Nitro Gas	12087GR	2
Foam Cell	24087FE	2
SPRING		
Upated Torsion Bar	HYUND004	1

REAR SUSPENSION

Product	Part Number	Qty Req'd
SHOCK ABSORBER		
Nitro Gas	<i>Comfort Soft Ride</i>	2
Nitro Gas	12637GR	2
COIL SPRING		
Performance	<i>Additional Weight</i> 0-300kg	1
DIFF BREATHER HOSE		
Extended Hose	DHOSE350	1

SUSPENSION KIT

Product	Part Number
Performance with Gas Shocks	HYUND003BKG

NOTE: Image above indicates kit contents.

Must install extended Diff Breather Hose #DHOSE350 when installing Ironman rear shock absorbers.

CHEROKEE

XJ
1994 On
40mm Lift



FRONT SUSPENSION

Product	Part Number	Qty Req'd	
SHOCK ABSORBER			
Nitro Gas	12665GR	2	
Foam Cell	24665FE	2	
COIL SPRING			
Performance	Additional Weight 0-100kg	JEEP016B	1
STEERING DAMPER			
Foam Cell	3540	1	

REAR SUSPENSION

Product	Part Number	Qty Req'd	
SHOCK ABSORBER			
Nitro Gas	12666GR	2	
Foam Cell	24666FE	2	
LEAF SPRING			
Performance	Additional Weight 0-250kg	JEEP004B	2
U-BOLTS			
U-Bolt Kit	512UBK	2	
POLYURETHANE SPRING BUSHES			
Complete Set	762UK	1	

SUSPENSION KIT

Product	Part Number
Performance with Gas Shocks	JEEP003BKG
Performance with Foam Cell Shocks	JEEP003BKF

NOTE: Image above indicates kit contents.

**In some cases, a Driveline vibration may occur after lift.
A Gearbox Crossmember Spacer Kit may be required.**



WRANGLER
TJ
10/1996 - 2/2007
40mm Lift

FRONT SUSPENSION

Product	Part Number	Qty Req'd	
SHOCK ABSORBER			
Nitro Gas	12665GR	2	
Foam Cell	24665FE	2	
COIL SPRING			
	Additional Weight		
Performance	0-40kg	JEEP007B	1
Constant Load	40-80kg	JEEP003B	1
STEERING DAMPER			
Foam Cell	3540	1	

REAR SUSPENSION

Product	Part Number	Qty Req'd	
SHOCK ABSORBER			
Nitro Gas	12669GR	2	
COIL SPRING			
	Additional Weight		
Performance	0-200kg	JEEP008B	1

SUSPENSION KIT

Product	Part Number
Performance with Gas Shocks	JEEP007BKG

NOTE: Image above indicates kit contents.

**In some cases, a Driveline vibration may occur after lift.
A Gearbox Crossmember Spacer Kit may be required.**

GRAND CHEROKEE

ZJ, ZG

4/1996 - 1999

40mm Lift



FRONT SUSPENSION

Product	Part Number	Qty Req'd	
SHOCK ABSORBER			
Nitro Gas	12665GR	2	
Foam Cell	24665FE	2	
COIL SPRING			
	Additional Weight		
Performance	0-50kg	JEEP003B	1
Constant Load	50-100kg	JEEP016B	1
STEERING DAMPER			
Foam Cell	3540	1	

REAR SUSPENSION

Product	Part Number	Qty Req'd	
SHOCK ABSORBER			
Nitro Gas	12670GR	2	
COIL SPRING			
	Additional Weight		
Performance	0-200kg	JEEP006B	1
Constant Load	200kg-GVM	JEEP003B	1

SUSPENSION KIT

Product	Part Number
Performance with Gas Shocks	JEEP006BKG
Constant Load with Gas Shocks	JEEP006CKG

NOTE: Image above indicates kit contents.



GRAND CHEROKEE
 WJ, WG
 1999 - 6/2005
 40mm Lift

FRONT SUSPENSION

Product	Part Number	Qty Req'd	
SHOCK ABSORBER			
Nitro Gas	12774GR	2	
COIL SPRING			
Performance	Additional Weight 0-50kg	JEEP012B	1

REAR SUSPENSION

Product	Part Number	Qty Req'd	
SHOCK ABSORBER			
Nitro Gas	12775GR	2	
COIL SPRING			
Performance	Additional Weight 0-200kg	JEEP013B	1

SUSPENSION KIT

Product	Part Number
Performance with Gas Shocks	JEEP012BKG

NOTE: Image above indicates kit contents.

CHEROKEE
LIBERTY KJ
 2001 On
 40mm Lift



FRONT SUSPENSION

Product		Part Number	Qty Req'd
SHOCK ABSORBER			
Nitro Gas	<i>Height Adjustable Strut</i>	12711GR	2
COIL SPRING			
	Additional Weight		
Performance / Petrol	<i>0-50kg</i>	JEEP014B	1
Constant Load or Diesel	<i>50-100kg</i>	JEEP014C	1
TRIM PACKER			
10mm Spacer	<i>Ironman Struts Only</i>	HILFR10	2
15mm Spacer	<i>Ironman Struts Only</i>	HILFR15	2

REAR SUSPENSION

Product		Part Number	Qty Req'd
SHOCK ABSORBER			
Nitro Gas		12712GR	2
COIL SPRING			
	Additional Weight		
Performance	<i>0-200kg</i>	JEEP015B	1

SUSPENSION KIT

Product	Part Number
Petrol with Gas Shocks	JEEP014BKG
Diesel with Gas Shocks	JEEP014BKG1

NOTE: Image above indicates kit contents.

**Unnecessary fitment of Trim Packers may lift vehicle too high.
 It is also essential to select the correct front coil springs to
 maintain a minimum of 60mm downward suspension travel.**

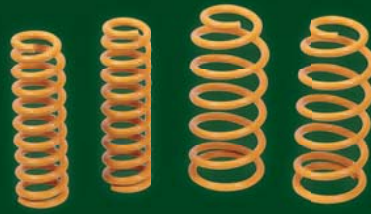

SORENTO

2003 - 6/2007

35mm Lift

FRONT SUSPENSION

Product	Additional Weight	Part Number	Qty Req'd
COIL SPRING			
Performance	0-50kg	KIA006B	1

REAR SUSPENSION

Product	Additional Weight	Part Number	Qty Req'd
COIL SPRING			
Performance	0-200kg	KIA007B	1

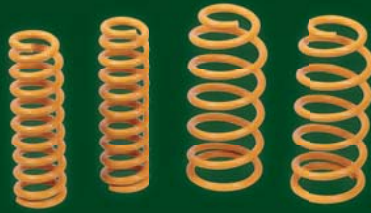

NIVA

1978 On

35mm Lift

FRONT SUSPENSION

Product	Additional Weight	Part Number	Qty Req'd
COIL SPRING			
Performance	0-50kg	LADA001B	1

REAR SUSPENSION

Product	Additional Weight	Part Number	Qty Req'd
COIL SPRING			
Performance	0-200kg	LADA002B	1

DEFENDER

90 SERIES

1984 On

45mm Lift

**FRONT SUSPENSION**

Product	Part Number	Qty Req'd
---------	-------------	-----------

SHOCK ABSORBER

Nitro Gas	12080GR	2
Foam Cell	24080FE	2

COIL SPRING**Additional Weight**

Performance	0-80kg	LAND009B	1
-------------	--------	----------	---

STEERING DAMPER

Foam Cell	3532	1
-----------	------	---

REAR SUSPENSION

Product	Part Number	Qty Req'd
---------	-------------	-----------

SHOCK ABSORBER

Nitro Gas	12640GR	2
Foam Cell	24640FE	2

COIL SPRING**Additional Weight**

Performance	0-300kg	LAND011B	1
Constant Load	300kg-GVM	LAND011C	1

BUSH KIT

Product	Part Number	Qty Req'd
---------	-------------	-----------

Suspension Arm Bush Kit	Chassis No. Up to LA930455	821K	1
Suspension Arm Bush Kit	Chassis No. LA930456 On	811K	1

SUSPENSION KIT

Product	Part Number
---------	-------------

Performance with Gas Shocks	LAND009BKG
Performance with Foam Cell Shocks	LAND009BKF
Constant Load with Gas Shocks	LAND009CKG
Constant Load with Foam Cell Shocks	LAND009CKF

NOTE: Image above indicates kit contents.



DEFENDER
110 TRAYBACK
1984 On
45mm Lift

FRONT SUSPENSION

Product	Part Number	Qty Req'd	
SHOCK ABSORBER			
Nitro Gas	12080GR	2	
Foam Cell	24080FE	2	
COIL SPRING			
Performance	Additional Weight 0-80kg	LAND007B	1
STEERING DAMPER			
Foam Cell	3532	1	

REAR SUSPENSION

Product	Part Number	Qty Req'd	
SHOCK ABSORBER			
Nitro Gas	12640GR	2	
Foam Cell	24640FE	2	
COIL SPRING			
Performance	Additional Weight 0-400kg	LAND006B	1
Constant Load	400kg-GVM	LAND006C	1

BUSH KIT

Product	Part Number	Qty Req'd	
Suspension Arm Bush Kit	Chassis No. Up to LA930455	821K	1
Suspension Arm Bush Kit	Chassis No. LA930456 On	811K	1

SUSPENSION KIT

Product	Part Number
Performance with Gas Shocks	LAND007BKG
Performance with Foam Cell Shocks	LAND007BKF
Constant Load with Gas Shocks	LAND007CKG
Constant Load with Foam Cell Shocks	LAND007CKF

NOTE: Image above indicates kit contents.

DEFENDER

110, 130 COUNTY / DUAL CAB

1984 On

45mm Lift



FRONT SUSPENSION

Product	Part Number	Qty Req'd
---------	-------------	-----------

SHOCK ABSORBER

Nitro Gas	12080GR	2
Foam Cell	24080FE	2

COIL SPRING

Additional Weight

Performance	0-80kg	LAND005B	1
-------------	--------	----------	---

STEERING DAMPER

Foam Cell	3532	1
-----------	------	---

REAR SUSPENSION

Product	Part Number	Qty Req'd
---------	-------------	-----------

SHOCK ABSORBER

Nitro Gas	12640GR	2
Foam Cell	24640FE	2

COIL SPRING

Additional Weight

With Self Levelling	0-300kg	LAND008B	1
Non Self Levelling	0-300kg	LAND006B	1
Constant Load Non Self Levelling	300kg-GVM	LAND006C	1

BUSH KIT

Product	Part Number	Qty Req'd
---------	-------------	-----------

Suspension Arm Bush Kit	Chassis No. Up to LA930434	821K	1
Suspension Arm Bush Kit	Chassis No. LA930435 On	811K	1

SUSPENSION KIT

Product	Part Number
---------	-------------

Self Levelling with Gas Shocks	LAND005BKG
Self Levelling with Foam Cell Shocks	LAND005BKF
Non Self Levelling with Gas Shocks	LAND006BKG
Non Self Levelling with Foam Cell Shocks	LAND006BKF
Constant Load Non Self Levelling with Gas Shocks	LAND006CKG
Constant Load Non Self Levelling with Foam Cell Shocks	LAND006CKF

NOTE: Image above indicates kit contents.



DISCOVERY
SERIES 1
 1989 - 1998
 40mm Lift



RANGEROVER
 1971 - 1995
 40mm Lift

FRONT SUSPENSION

Product		Part Number	Qty Req'd
SHOCK ABSORBER			
Nitro Gas		12080GR	2
Foam Cell		24080FE	2
COIL SPRING			
	Additional Weight		
Performance	0-50kg	LAND009B	1
Constant Load	50-110kg	LAND007B	1
STEERING DAMPER			
Foam Cell		3511	1

REAR SUSPENSION

Product		Part Number	Qty Req'd
SHOCK ABSORBER			
Nitro Gas		12640GR	2
Foam Cell		24640FE	2
COIL SPRING			
	Additional Weight		
Performance	0-300kg	LAND011B	1
Constant Load	300kg-GVM	LAND011C	1

BUSH KIT

Product		Part Number	Qty Req'd
Suspension Arm Bush Kit	Pre 1986	801K	1
Suspension Arm Bush Kit	1986 On	811K	1

SUSPENSION KIT

Product	Part Number
Performance with Gas Shocks	LAND009BKG
Performance with Foam Cell Shocks	LAND009BKF
Constant Load with Gas Shocks	LAND009CKG
Constant Load with Foam Cell Shocks	LAND009CKF

NOTE: Image above indicates kit contents.

DISCOVERY
SERIES 2, TD5
 1999 - 2005
 40mm Lift



FRONT SUSPENSION

Product	Part Number	Qty Req'd	
SHOCK ABSORBER			
Nitro Gas	12776GR	2	
Foam Cell	24776FE	2	
COIL SPRING			
	Additional Weight		
Performance	0-50kg	LAND014B	1
Constant Load	50-100kg	LAND009B	1
STEERING DAMPER			
Foam Cell	3502	1	

REAR SUSPENSION

Product	Part Number	Qty Req'd	
SHOCK ABSORBER			
Nitro Gas	12777GR	2	
Foam Cell	24777FE	2	
COIL SPRING			
	Additional Weight		
Performance	0-300kg	LAND011B	1
Constant Load	300kg-GVM	LAND011C	1

SUSPENSION KIT

Product	Part Number
Performance with Gas Shocks	LAND014BKG
Performance with Foam Cell Shocks	LAND014BKF
Constant Load with Gas Shocks	LAND014CKG
Constant Load with Foam Cell Shocks	LAND014CKF

NOTE: Image above indicates kit contents.



BRAVO & RAIDER

1987 On
40mm Lift

FRONT SUSPENSION

Product	Part Number	Qty Req'd
SHOCK ABSORBER		
Nitro Gas	12667GR	2
Foam Cell	24667FE	2
SPRING		
Up-rated Torsion Bar	MAZDA005	1

REAR SUSPENSION

Product	Part Number	Qty Req'd	
SHOCK ABSORBER			
Nitro Gas	12095GR	2	
Foam Cell	24095FE	2	
LEAF SPRING			
	Additional Weight		
Comfort	0-100kg	MAZDA006A	2
Performance	0-200kg	MAZDA006B	2
Constant Load	200-400kg	MAZDA006C	2
Mining	400kg-GVM	MAZDA006D	2
U-BOLTS			
U-Bolt Kit	415UBK	2	
POLYURETHANE SPRING BUSHES			
Complete Set	756UK	1	
GREASABLE SHACKLES & PINS			
Greasable Shackle	386-1	2	
Greasable Pin	794	2	

SUSPENSION KIT

Product	Part Number
Comfort with Gas Shocks	MAZDA006AKG
Comfort with Foam Cell Shocks	MAZDA006AKF
Performance with Gas Shocks	MAZDA006BKG
Performance with Foam Cell Shocks	MAZDA006BKF
Constant Load with Gas Shocks	MAZDA006CKG
Constant Load with Foam Cell Shocks	MAZDA006CKF
Mining with Gas Shocks	MAZDA006DKG
Mining with Foam Cell Shocks	MAZDA006DKF

NOTE: Image above indicates kit contents.

BT50
2006 On
40mm Lift



FRONT SUSPENSION

Product	Part Number	Qty Req'd
SHOCK ABSORBER		
Nitro Gas	12667GR	2
Foam Cell	24667FE	2
SPRING		
Up-rated Torsion Bar	MAZDA014	1

REAR SUSPENSION

Product	Part Number	Qty Req'd	
SHOCK ABSORBER			
Nitro Gas	12095GR	2	
Foam Cell	24095FE	2	
LEAF SPRING			
	Additional Weight		
Comfort	0-100kg	MAZDA041A	2
Performance	0-200kg	MAZDA041B	2
Constant Load	200-400kg	MAZDA041C	2
Mining	400kg-GVM	MAZDA041D	2
U-BOLTS			
U-Bolt Kit	417UBK	2	
POLYURETHANE SPRING BUSHES			
Complete Set	759UK	1	
GREASABLE SHACKLES & PINS			
Greasable Shackle	386-1	2	

SUSPENSION KIT

Product	Part Number
Comfort with Gas Shocks	MAZDA041AKG
Comfort with Foam Cell Shocks	MAZDA041AKF
Performance with Gas Shocks	MAZDA041BKG
Performance with Foam Cell Shocks	MAZDA041BKF
Constant Load with Gas Shocks	MAZDA041CKG
Constant Load with Foam Cell Shocks	MAZDA041CKF
Mining Load with Gas Shocks	MAZDA041DKG
Mining Load with Foam Cell Shocks	MAZDA041DKF

NOTE: Image above indicates kit contents.



TRITON
ME, MF, MG, MH, MJ
1993 - 1996
40mm Lift

FRONT SUSPENSION

Product	Part Number	Qty Req'd
SHOCK ABSORBER		
Nitro Gas	12082GR	2
Foam Cell	24082FE	2
SPRING		
Uprated Torsion Bar	MITS015C	1
STEERING DAMPER		
Foam Cell	<i>Non Power Steering Models Only</i>	3517

REAR SUSPENSION

Product	Part Number	Qty Req'd
SHOCK ABSORBER		
Nitro Gas	<i>Comfort Soft Ride</i>	12698GRC
Nitro Gas		12698GR
Foam Cell		24698FE
LEAF SPRING		
Comfort	<i>0-100kg</i>	MITS018A
Performance	<i>0-300kg</i>	MITS018B
Constant Load	<i>300kg-GVM</i>	MITS018C
U-BOLTS		
U-Bolt Kit		451UBK
POLYURETHANE SPRING BUSHES		
Complete Set		715TUK
GREASABLE SHACKLES & PINS		
Greasable Shackle		795
Non Greasable Pin		387-1

SUSPENSION KIT

Product	Part Number
Comfort with Gas Shocks	MITS015AKG
Comfort with Foam Cell Shocks	MITS015AKF
Performance with Gas Shocks	MITS015BKG
Performance with Foam Cell Shocks	MITS015BKF
Constant Load with Gas Shocks	MITS015CKG
Constant Load with Foam Cell Shocks	MITS015CKF

NOTE: Image above indicates kit contents.

TRITON
MK
 1996-2005
 40mm Lift



FRONT SUSPENSION

Product	Part Number	Qty Req'd
SHOCK ABSORBER		
Nitro Gas	12087GR	2
Foam Cell	24087FE	2
SPRING		
Up-rated Torsion Bar	MITS015C	1
STEERING DAMPER		
Foam Cell	<i>Non Power Steering Models Only</i>	3517

REAR SUSPENSION

Product	Part Number	Qty Req'd
SHOCK ABSORBER		
Nitro Gas	<i>Comfort Soft Ride</i>	12698GRC
Nitro Gas		12698GR
Foam Cell		24698FE
LEAF SPRING		
	Additional Weight	
Comfort	<i>0-100kg</i>	MITS018A
Performance	<i>0-300kg</i>	MITS018B
Constant Load	<i>300kg-GVM</i>	MITS018C
U-BOLTS		
U-Bolt Kit	451UBK	2
POLYURETHANE SPRING BUSHES		
Complete Set	715TUK	1
GREASABLE SHACKLES & PINS		
Greasable Shackle	795	2
Non Greasable Pin	387-1	2

SUSPENSION KIT

Product	Part Number
Comfort with Gas Shocks	MITS015AKG1
Comfort with Foam Cell Shocks	MITS015AKF1
Performance with Gas Shocks	MITS015BKG1
Performance with Foam Cell Shocks	MITS015BKF1
Constant Load with Gas Shocks	MITS015CKG1
Constant Load with Foam Cell Shocks	MITS015CKF1

NOTE: Image above indicates kit contents.



TRITON
ML
8/2005 On
40mm Lift*

FRONT SUSPENSION

Product		Part Number	Qty Req'd
SHOCK ABSORBER			
Nitro Gas	<i>Height Adjustable Strut</i>	12715GR	2
COIL SPRING			
	Additional Weight		
Performance	<i>0-80kg</i>	MITS040B	1
Constant Load	<i>80-120kg</i>	MITS040C	1
TRIM PACKER			
10mm Spacer	<i>Ironman Struts Only</i>	HILFR10	2
15mm Spacer	<i>Ironman Struts Only</i>	HILFR15	2

REAR SUSPENSION

Product		Part Number	Qty Req'd
SHOCK ABSORBER			
Nitro Gas	<i>Comfort Soft Ride</i>	12636GRC	2
Nitro Gas		12636GR	2
LEAF SPRING			
	Additional Weight		
Comfort	<i>0-200kg</i>	MITS041A	2
Performance, *25mm Lift	<i>0-300kg</i>	MITS041B	2
Constant Load	<i>300kg-GVM</i>	MITS041C	2
U-BOLTS			
U-Bolt Kit		1102UBK	2
POLYURETHANE SPRING BUSHES			
Complete Set		715TUK	1
GREASABLE SHACKLES & PINS			
Greasable Shackle		795	2
Non Greasable Pin		387-1	2

SUSPENSION KIT

Product	Part Number
Comfort with Gas Shocks - <i>Check Front Coil</i>	MITS041AKG
Performance with Gas Shocks - <i>Check Front Coil</i>	MITS041BKG
Constant Load with Gas Shocks - <i>Check Front Coil</i>	MITS041CKG

NOTE: Image above indicates kit contents.

It is essential to select the correct front coil springs to maintain a minimum of 60mm downward suspension travel.
All unladen manual vehicles must use MITS041B Rear Leaf Spring.

PAJERO / MONTERO

NA - NG, L200 TRITON

Leaf Springs Rear, 1983 - 1992

40mm Lift



FRONT SUSPENSION

Product		Part Number	Qty Req'd
SHOCK ABSORBER			
Nitro Gas	<i>Pre 6/1991</i>	12082GR	2
Foam Cell	<i>Pre 6/1991</i>	24082FE	2
SPRING			
Uprated Torsion Bar		MITS013	1
STEERING DAMPER			
Foam Cell	<i>Non Power Steering Models Only</i>	3517	1

REAR SUSPENSION

Product		Part Number	Qty Req'd
SHOCK ABSORBER			
Nitro Gas	<i>Comfort Soft Ride</i>	12636GRC	2
Nitro Gas		12636GR	2
Foam Cell		24636FE	2
LEAF SPRING			
	Additional Weight		
Comfort	<i>0-100kg</i>	MITS018A	2
Performance	<i>0-300kg</i>	MITS018B	2
Constant Load	<i>300kg-GVM</i>	MITS018C	2
U-BOLTS			
U-Bolt Kit		451UBK	2
POLYURETHANE SPRING BUSHES			
Complete Set		715UK	1
GREASABLE SHACKLES & PINS			
Greasable Shackle		795	2
Greasable Pin		796	2

SUSPENSION KIT

Product	Part Number
Comfort with Gas Shocks	MITS018AKG1
Comfort with Foam Cell Shocks	MITS018AKF1
Performance with Gas Shocks	MITS018BKG1
Performance with Foam Cell Shocks	MITS018BKF1
Constant Load with Gas Shocks	MITS018CKG1
Constant Load with Foam Cell Shocks	MITS018CKF1

NOTE: Image above indicates kit contents.



PAJERO / MONTERO

NH-NL

Leaf Springs Rear, 1992 - 1996

40mm Lift

FRONT SUSPENSION

Product		Part Number	Qty Req'd
SHOCK ABSORBER			
Nitro Gas	7/1991 On	12087GR	2
Foam Cell	7/1991 On	24087FE	2
SPRING			
Uprated Torsion Bar		MITS013	1
STEERING DAMPER			
Foam Cell	Non Power Steering Models Only	3517	1

REAR SUSPENSION

Product		Part Number	Qty Req'd
SHOCK ABSORBER			
Nitro Gas	Comfort Soft Ride	12636GRC	2
Nitro Gas		12636GR	2
Foam Cell		24636FE	2
LEAF SPRING			
	Additional Weight		
Comfort	0-100kg	MITS018A	2
Performance	0-300kg	MITS018B	2
Constant Load	300kg-GVM	MITS018C	2
U-BOLTS			
U-Bolt Kit		451UBK	2
POLYURETHANE SPRING BUSHES			
Complete Set		715UK	1
GREASABLE SHACKLES & PINS			
Greasable Shackle		795	2
Greasable Pin		796	2

SUSPENSION KIT

Product	Part Number
Comfort with Gas Shocks	MITS018AKG2
Comfort with Foam Cell Shocks	MITS018AKF2
Performance with Gas Shocks	MITS018BKG2
Performance with Foam Cell Shocks	MITS018BKF2
Constant Load with Gas Shocks	MITS018CKG2
Constant Load with Foam Cell Shocks	MITS018CKF2

NOTE: Image above indicates kit contents.

PAJERO / MONTERO

NF, NG SWB & LWB

Coil Springs Rear, 1988 - 5/1991

40mm Lift



FRONT SUSPENSION

Product		Part Number	Qty Req'd
SHOCK ABSORBER			
Nitro Gas	<i>Pre 5/1991</i>	12082GR	2
Foam Cell	<i>Pre 5/1991</i>	24082FE	2
SPRING			
Up-rated Torsion Bar	<i>Check Length 1278mm</i>	MITS013	1
Up-rated Torsion Bar	<i>Check Length 1308mm</i>	MITS019	1
STEERING DAMPER			
Foam Cell	<i>Non Power Steering Models Only</i>	3517	1

REAR SUSPENSION

Product		Part Number	Qty Req'd
SHOCK ABSORBER			
Nitro Gas	<i>Pre 5/1991</i>	12645GR	2
Foam Cell	<i>Pre 5/1991</i>	24645FE	2
COIL SPRING			
	Additional Weight		
Performance SWB	<i>0-250kg</i>	MITS022B	1
Performance LWB	<i>0-250kg</i>	MITS020B	1

SUSPENSION KIT

Product		Part Number
SWB with Gas Shocks	<i>Check Torsion Bar Length</i>	MITS022BKG1
SWB with Foam Cell Shocks	<i>Check Torsion Bar Length</i>	MITS022BKF1
LWB with Gas Shocks	<i>Check Torsion Bar Length</i>	MITS020BKG1
LWB with Foam Cell Shocks	<i>Check Torsion Bar Length</i>	MITS020BKF1

NOTE: Image above indicates kit contents.



PAJERO
 NH - NL, SWB & LWB
 Coil Springs Rear, 6/1991 - 2000
 40mm Lift

FRONT SUSPENSION

Product		Part Number	Qty Req'd
SHOCK ABSORBER			
Nitro Gas	6/1991 On	12087GR	2
Foam Cell	6/1991 On	24087FE	2
SPRING			
Up-rated Torsion Bar	Check Length 1278mm	MITS013	1
Up-rated Torsion Bar	Check Length 1308mm	MITS019	1
STEERING DAMPER			
Foam Cell	Non Power Steering Models Only	3517	1

REAR SUSPENSION

Product		Part Number	Qty Req'd
SHOCK ABSORBER			
Nitro Gas	6/1991 On	12646GR	2
Foam Cell	6/1991 On	24646FE	2
COIL SPRING			
	Additional Weight		
Performance SWB	0-250kg	MITS022B	1
Performance LWB	0-250kg	MITS020B	1

SUSPENSION KIT

Product		Part Number
SWB with Gas Shocks	Check Torsion Bar Length	MITS022BKG2
SWB with Foam Cell Shocks	Check Torsion Bar Length	MITS022BKF2
LWB with Gas Shocks	Check Torsion Bar Length	MITS020BKG2
LWB with Foam Cell Shocks	Check Torsion Bar Length	MITS020BKF2

NOTE: Image above indicates kit contents.

PAJERO / MONTERO

NM, NP, NS, NT

2000 On

40mm Lift



FRONT SUSPENSION

Product		Part Number	Qty Req'd
SHOCK ABSORBER			
Nitro Gas	Strut	12713GR	2
COIL SPRING			
	Additional Weight		
Petrol	0-50kg	MITS038B	1
Constant Load or Diesel	50-100kg	MITS038C	1

REAR SUSPENSION

Product		Part Number	Qty Req'd
SHOCK ABSORBER			
Nitro Gas		12714GR	2
COIL SPRING			
	Additional Weight		
Performance SWB	0-200kg	MITS039A	1
Performance LWB	0-200kg	MITS039B	1

SUSPENSION KIT

Product	Part Number
SWB with Gas Shocks	MITS038AKG
LWB Petrol with Gas Shocks	MITS038BKG
LWB Diesel with Gas Shocks	MITS038CKG

NOTE: Image above indicates kit contents.

It is essential to select the correct front coil springs to maintain a minimum of 60mm downward suspension travel.



FRONT SUSPENSION

Product	Part Number	Qty Req'd
SHOCK ABSORBER		
Nitro Gas	12087GR	2
Foam Cell	24087FE	2
SPRING		
Up-rated Torsion Bar	MITSO19	1

REAR SUSPENSION

Product	Part Number	Qty Req'd	
SHOCK ABSORBER			
Nitro Gas	<i>Comfort Soft Ride</i>	12636GRC	2
Nitro Gas		12636GR	2
Foam Cell		24636FE	2
LEAF SPRING			
	Additional Weight		
Comfort	<i>0-100kg</i>	MITSO18A	2
Performance	<i>0-300kg</i>	MITSO18B	2
Constant Load	<i>300kg-GVM</i>	MITSO18C	2
U-BOLTS			
U-Bolt Kit	451UBK	2	
POLYURETHANE SPRING BUSHES			
Complete Set	715STUK	1	
GREASABLE SHACKLES & PINS			
Greasable Shackle	795	2	

SUSPENSION KIT

Product	Part Number
Performance with Gas Shocks	MITSO18AKG
Performance with Foam Cell Shocks	MITSO18AKF
Constant Load with Gas Shocks	MITSO18BKG
Constant Load with Foam Cell Shocks	MITSO18BKF
Extra Constant Load with Gas Shocks	MITSO18CKG
Extra Constant Load with Foam Cell Shocks	MITSO18CKF

NOTE: Image above indicates kit contents.

CHALLENGER
PA MONTERO SPORT
 Coil Springs Rear, 1998 On
 40mm Lift



FRONT SUSPENSION

Product	Part Number	Qty Req'd
SHOCK ABSORBER		
Nitro Gas	12087GR	2
Foam Cell	24087FE	2
SPRING		
Upated Torsion Bar	MITS019	1

REAR SUSPENSION

Product	Part Number	Qty Req'd
SHOCK ABSORBER		
Nitro Gas	<i>Coil Spring Models</i> 12645GR	2
Foam Cell	<i>Coil Spring Models</i> 24645FE	2
COIL SPRING		
Performance	<i>Additional Weight</i> 0-250kg	MITS022B 1
Constant Load	250kg-GVM	MITS020B 1

SUSPENSION KIT

Product	Part Number
Performance with Gas Shocks	MITS022BKG
Performance with Foam Cell Shocks	MITS022BKF
Constant Load with Gas Shocks	MITS020BKG
Constant Load with Foam Cell Shocks	MITS020BKF

NOTE: Image above indicates kit contents.



DELICA
 L400
 5/1994 On
 40mm Lift

FRONT SUSPENSION

Product	Part Number	Qty Req'd
SHOCK ABSORBER		
Nitro Gas	12667GR	2
Foam Cell	24667FE	2
SPRING		
Up rated Torsion Bar	5/1994 - 5/1999 MITS031	1

REAR SUSPENSION

Product	Part Number	Qty Req'd
SHOCK ABSORBER		
Nitro Gas	<i>Without Electronic Suspension</i> 12698GR	2
Nitro Gas	<i>With Electronic Suspension</i> 12671GR	2
COIL SPRING		
Performance	Additional Weight <i>0-250kg</i> MITS025B	1

SUSPENSION KIT

Product	Part Number
Performance with Gas Shocks - <i>Without ECS</i>	MITS031BKG
Performance with Gas Shocks - <i>With ECS</i>	MITS031BKG1

NOTE: *Ironman Shock Absorber does not reconnect to ECS system.*

NOTE: *Image above indicates kit contents.*

PATROL
MQ G160
 Round Headlights, Pre 1984
 45mm Lift



FRONT SUSPENSION

Product		Part Number	Qty Req'd
SHOCK ABSORBER			
Nitro Gas		12075GR	2
LEAF SPRING			
	Additional Weight		
Performance Drivers Side	0-50kg	NISS003BD/S	1
Performance Near Side	0-50kg	NISS003BN/S	1
STEERING DAMPER			
Foam Cell		3522	1
U-BOLTS			
U-Bolt Kit	<i>Drivers Side</i>	452UBK	1
U-Bolt Kit	<i>Near Side</i>	451UBK	1
POLYURETHANE SPRING BUSHES			
Complete Set		721UK	1
GREASABLE SHACKLES & PINS			
Greasable Shackle	<i>Straight Side Plates</i>	355K	2
Greasable Pin		470	2

REAR SUSPENSION

Product		Part Number	Qty Req'd
SHOCK ABSORBER			
Nitro Gas		12076GR	2
LEAF SPRING			
	Additional Weight		
Performance Drivers Side	0-200kg	NISS004BD/S	1
Performance Near Side	0-200kg	NISS004BN/S	1
U-BOLTS			
U-Bolt Kit		453UBK	2
POLYURETHANE SPRING BUSHES			
Complete Set		722UK	1
GREASABLE SHACKLES & PINS			
Greasable Shackle		664	2
Greasable Pin		470	2

SUSPENSION KIT

Product	Part Number
Performance with Gas Shocks	NISS003BKG

NOTE: Image above indicates kit contents.



PATROL

MK G160

Square Headlights, 1984 - 1988

45mm Lift

FRONT SUSPENSION

Product		Part Number	Qty Req'd
SHOCK ABSORBER			
Nitro Gas		12075GR	2
LEAF SPRING			
	Additional Weight		
Performance Drivers Side	0-50kg	NISS005BD/S	1
Performance Near Side	0-50kg	NISS005BN/S	1
STEERING DAMPER			
Foam Cell		3522	1
U-BOLTS			
U-Bolt Kit	<i>Drivers Side</i>	452UBK	1
U-Bolt Kit	<i>Near Side</i>	451UBK	1
POLYURETHANE SPRING BUSHES			
Complete Set		724UK	1
GREASABLE SHACKLES & PINS			
Greasable Shackle	<i>Stepped Side Plates</i>	665	2
Greasable Pin		470	2

REAR SUSPENSION

Product		Part Number	Qty Req'd
SHOCK ABSORBER			
Nitro Gas		12076GR	2
LEAF SPRING			
	Additional Weight		
Performance Drivers Side	0-200kg	NISS004BD/S	1
Performance Near Side	0-200kg	NISS004BN/S	1
U-BOLTS			
U-Bolt Kit		453UBK	2
POLYURETHANE SPRING BUSHES			
Complete Set		722UK	1
GREASABLE SHACKLES & PINS			
Greasable Shackle		664	2
Greasable Pin		470	2

SUSPENSION KIT

Product	Part Number
Performance with Gas Shocks	NISS005BKG

NOTE: Image above indicates kit contents.

PATROL
GQ Y60 SWB WAGON
1988 - 1998
45mm Lift



FRONT SUSPENSION

Product		Part Number	Qty Req'd
SHOCK ABSORBER			
Nitro Gas		12091GR	2
Foam Cell		24091FE	2
COIL SPRING			
	Additional Weight		
Performance	0-50kg	NISS007B	1
Constant Load	50-110kg	NISS009B	1
STEERING DAMPER			
Foam Cell	Pre 8/1989	3534	1
Foam Cell	Post 8/1989	3536	1
OFFSET CASTER BUSH KIT			
Offset Bush Kit	2 Degree	1144SK	1
GEARBOX PACKER			
Crossmember Spacer Kit		1002K	1
TRIM PACKER			
15mm Coil Spring Trim Packer		PATF15	2
30mm Coil Spring Trim Packer		PATF30	2

REAR SUSPENSION

Product		Part Number	Qty Req'd
SHOCK ABSORBER			
Nitro Gas		12094GR	2
Foam Cell		24094FE	2
COIL SPRING			
	Additional Weight		
Performance	0-200kg	NISS008B	1
Constant Load	200kg-GVM	NISS010B	1
TRIM PACKER			
15mm Coil Spring Trim Packer	Ride Height +10mm	PATR15	2
30mm Coil Spring Trim Packer	Ride Height +25mm	PATR30	2

BUSH KIT

Product		Part Number	Qty Req'd
Suspension Arm Bush Kit	Pre 1989	831K	1
Suspension Arm Bush Kit	1989 On	839K	1

SUSPENSION KIT

Product	Part Number
Performance with Gas Shocks	NISS007BKG
Performance with Foam Cell Shocks	NISS007BKF
Constant Load with Gas Shocks	NISS009BKG
Constant Load with Foam Cell Shocks	NISS009BKF

NOTE: Image above indicates kit contents.



PATROL
GQ Y60 LWB WAGON
 1988 - 1998
 50mm Lift

FRONT SUSPENSION

Product		Part Number	Qty Req'd
SHOCK ABSORBER			
Nitro Gas		12091GR	2
Foam Cell		24091FE	2
COIL SPRING			
	Additional Weight		
Performance	0-50kg	NISS009B	1
Constant Load	50-110kg	NISS009C	1
STEERING DAMPER			
Foam Cell	Pre 8/1989	3534	1
Foam Cell	Post 8/1989	3536	1
OFFSET CASTER BUSH KIT			
Offset Bush Kit	2 Degree	1144SK	1
GEARBOX PACKER			
Crossmember Spacer Kit		1002K	1
TRIM PACKER			
15mm Coil Spring Trim Packer		PATF15	2
30mm Coil Spring Trim Packer		PATF30	2

REAR SUSPENSION

Product		Part Number	Qty Req'd
SHOCK ABSORBER			
Nitro Gas		12094GR	2
Foam Cell		24094FE	2
COIL SPRING			
	Additional Weight		
Performance	0-200kg	NISS010B	1
Constant Load	200-400kg	NISS010C	1
Extra Constant Load	400-500kg	NISS020C	1
Mining	500kg-GVM	NISS020D	1
TRIM PACKER			
15mm Coil Spring Trim Packer	Ride Height +10mm	PATR15	2
30mm Coil Spring Trim Packer	Ride Height +25mm	PATR30	2

BUSH KIT

Product		Part Number	Qty Req'd
Suspension Arm Bush Kit	Pre 1989	831K	1
Suspension Arm Bush Kit	1989 On	839K	1

SUSPENSION KIT

Product	Part Number
Performance with Gas Shocks	NISS009BKG
Performance with Foam Cell Shocks	NISS009BKF
Constant Load with Gas Shocks	NISS009CKG
Constant Load with Foam Cell Shocks	NISS009CKF
Extra Constant Load with Gas Shocks	NISS020CKG
Extra Constant Load with Foam Cell Shocks	NISS020CKF
Mining with Gas Shocks	NISS024DKG
Mining with Foam Cell Shocks	NISS024DKF

NOTE: Image above indicates kit contents.

NOTE: For competition vehicle / big lift applications - see Page 94.

PATROL

GQ Y60 CAB CHASSIS AND UTE
Leaf Springs Front & Rear, 1988 On
50mm Lift



FRONT SUSPENSION

Product		Part Number	Qty Req'd
SHOCK ABSORBER			
Nitro Gas		12661GR	2
Foam Cell		24661FE	2
LEAF SPRING			
	Additional Weight		
Drivers Side	0-110kg	NISS011CD/S	1
Near Side	0-110kg	NISS011CN/S	1
STEERING DAMPER			
Foam Cell		3522	1
U-BOLTS			
U-Bolt Kit	<i>Drivers Side</i>	669UBK	1
U-Bolt Kit	<i>Near Side</i>	668UBK	1
POLYURETHANE SPRING BUSHES			
Complete Set		718UK	1
GREASABLE SHACKLES & PINS			
Greasable Shackle	<i>Right Side</i>	353LH	1
Greasable Shackle	<i>Left Side</i>	353RH	1
Greasable Pin		667	2

REAR SUSPENSION

Product		Part Number	Qty Req'd
SHOCK ABSORBER			
Nitro Gas		12648GR	2
Foam Cell		24648FE	2
LEAF SPRING			
	Additional Weight		
Drivers Side	0-400kg	NISS012CD/S	1
Near Side	0-400kg	NISS012CN/S	1
Mining Drivers Side	400kg-GVM	NISS012DD/S	1
Mining Near Side	400kg-GVM	NISS012DN/S	1
U-BOLTS			
U-Bolt Kit		670UBK	2
POLYURETHANE SPRING BUSHES			
Complete Set		719UK	1
GREASABLE SHACKLES & PINS			
Greasable Shackle	<i>Left Side</i>	353LH	1
Greasable Shackle	<i>Right Side</i>	353RH	1
Greasable Pin		667	2

SUSPENSION KIT

Product	Part Number
Constant Load with Gas Shocks	NISS011CKG
Constant Load with Foam Cell Shocks	NISS011CKF
Mining with Gas Shocks	NISS011DKG
Mining with Foam Cell Shocks	NISS011DKF

NOTE: Image above indicates kit contents.



PATROL
GU Y61 WAGON
 1997 On
 50mm Lift

FRONT SUSPENSION

Product		Part Number	Qty Req'd
SHOCK ABSORBER			
Nitro Gas		12091GR	2
Foam Cell		24091FE	2
COIL SPRING			
	Additional Weight		
Performance	0-50kg	NISS024B	1
Constant Load	50-110kg	NISS009C	1
STEERING DAMPER			
Foam Cell	Pre 2/2000	3511	1
Foam Cell	2/2000 On	3501	1
OFFSET CASTER BUSH KIT			
Offset Bush Kit	2 Degree	1144SK	1
TRIM PACKER			
15mm Coil Spring Trim Packer		PATF15	2
30mm Coil Spring Trim Packer		PATF30	2

REAR SUSPENSION

Product		Part Number	Qty Req'd
SHOCK ABSORBER			
Nitro Gas		12094GR	2
Foam Cell		24094FE	2
COIL SPRING			
	Additional Weight		
Performance	0-200kg	NISS010C	1
Constant Load	200-400kg	NISS020C	1
Extra Constant Load	400kg-GVM	NISS020D	1
TRIM PACKER			
15mm Coil Spring Trim Packer	Ride Height +10mm	PATR15	2
30mm Coil Spring Trim Packer	Ride Height +25mm	PATR30	2

SUSPENSION KIT

Product	Part Number
Performance with Gas Shocks	NISS024CKG
Performance with Foam Cell Shocks	NISS024CKF
Constant Load with Gas Shocks	NISS037CKG
Constant Load with Foam Cell Shocks	NISS037CKF
Extra Constant Load with Gas Shocks	NISS037DKG
Extra Constant Load with Foam Cell Shocks	NISS037DKF

NOTE: Image above indicates kit contents.

NOTE: For competition vehicle / big lift applications - see Page 94.

PATROL

GU Y61 CAB CHASSIS AND UTE
Coil Springs & Leaf Springs, 1997 On
50mm Lift



FRONT SUSPENSION

Product	Part Number	Qty Req'd
---------	-------------	-----------

SHOCK ABSORBER

Nitro Gas	12091GR	2
Foam Cell	24091FE	2

COIL SPRING	Additional Weight	Part Number	Qty
-------------	-------------------	-------------	-----

Performance	0-50kg	NISS024B	1
Constant Load	50-110kg	NISS009C	1

STEERING DAMPER

Foam Cell	3511	1
-----------	------	---

OFFSET CASTER BUSH KIT

Offset Bush Kit	2 Degree	1144SK	1
-----------------	----------	--------	---

TRIM PACKER

15mm Coil Spring Trim Packer	PATF15	2
30mm Coil Spring Trim Packer	PATF30	2

REAR SUSPENSION

Product	Part Number	Qty Req'd
---------	-------------	-----------

SHOCK ABSORBER

Nitro Gas	12648GR	2
Foam Cell	24648FE	2

LEAF SPRING	Additional Weight	Part Number	Qty
-------------	-------------------	-------------	-----

Drivers Side	0-400kg	NISS012CD/S	1
Near Side	0-400kg	NISS012CN/S	1
Mining Drivers Side	400kg-GVM	NISS012DD/S	1
Mining Near Side	400kg-GVM	NISS012DN/S	1

U-BOLTS

U-Bolt Kit	1100UBK	2
------------	---------	---

POLYURETHANE SPRING BUSHES

Complete Set	719UK	1
--------------	-------	---

GREASABLE SHACKLES & PINS

Greasable Shackle	Left Side	353LH	1
Greasable Shackle	Right Side	353RH	1
Greasable Pin		667	2

SUSPENSION KIT

Product	Part Number
---------	-------------

Performance with Gas Shocks	NISS036CKG
Performance with Foam Cell Shocks	NISS036CKF
Mining with Gas Shocks	NISS036DKG
Mining with Foam Cell Shocks	NISS036DKF

NOTE: Image above indicates kit contents.



PATROL
GU Y61 CAB CHASSIS AND UTE
 Coil Springs Front & Rear, 1997 On
 50mm Lift

FRONT SUSPENSION

Product	Part Number	Qty Req'd
---------	-------------	-----------

SHOCK ABSORBER

Nitro Gas	12091GR	2
Foam Cell	24091FE	2

COIL SPRING **Additional Weight**

Performance	0-50kg	NISS024B	1
Constant Load	50-110kg	NISS009C	1

STEERING DAMPER

Foam Cell	3511	1
-----------	------	---

OFFSET CASTER BUSH KIT

Offset Bush Kit	2 Degree	1144SK	1
-----------------	----------	--------	---

TRIM PACKER

15mm Coil Spring Trim Packer		PATF15	2
30mm Coil Spring Trim Packer		PATF30	2

REAR SUSPENSION

Product	Part Number	Qty Req'd
---------	-------------	-----------

SHOCK ABSORBER

Nitro Gas	12094GR	2
Foam Cell	24094FE	2

COIL SPRING **Additional Weight**

Performance	0-300kg	NISS020B	1
Constant Load	300-400kg	NISS020C	1
Mining	400kg-GVM	NISS020D	1

TRIM PACKER

15mm Coil Spring Trim Packer	Ride Height +10mm	PATR15	2
30mm Coil Spring Trim Packer	Ride Height +25mm	PATR30	2

SUSPENSION KIT

Product	Part Number
---------	-------------

Performance with Gas Shocks	NISS037BKG
Performance with Foam Cell Shocks	NISS037BKF
Constant Load with Gas Shocks	NISS037CKG
Constant Load with Foam Cell Shocks	NISS037CKF
Mining with Gas Shocks	NISS037DKG
Mining with Foam Cell Shocks	NISS037DKF

NOTE: Image above indicates kit contents.

NOTE: For competition vehicle / big lift applications - see Page 94.

PATHFINDER & TERRANO

WD21, R20
1987 - 1995
40mm Lift



FRONT SUSPENSION

Product	Part Number	Qty Req'd
SHOCK ABSORBER		
Nitro Gas	12667GR	2
Foam Cell	24667FE	2
SPRING		
Up-rated Torsion Bar	NISS017	1
STEERING DAMPER		
Foam Cell	<i>Equipped Models Only</i>	3535

REAR SUSPENSION

Product	Part Number	Qty Req'd	
SHOCK ABSORBER			
Nitro Gas	<i>Comfort Soft Ride</i>	12636GRC	2
Nitro Gas		12636GR	2
Foam Cell		24636FE	2
COIL SPRING			
Performance	<i>Additional Weight</i> <i>0-250kg</i>	NISS018B	1

SUSPENSION KIT

Product	Part Number
Performance with Gas Shocks	NISS018BKG
Performance with Foam Cell Shocks	NISS018BKF

NOTE: Image above indicates kit contents.

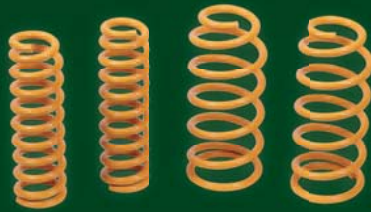

PATHFINDER

R50
1995 On
35mm Lift

FRONT SUSPENSION

Product	Additional Weight	Part Number	Qty Req'd
COIL SPRING			
Performance	0-50kg	NISS034B	1

REAR SUSPENSION

Product	Additional Weight	Part Number	Qty Req'd
COIL SPRING			
Performance	0-200kg	NISS035B	1

PATHFINDER

R51
7/2005 On
40mm Lift



FRONT SUSPENSION

Product		Part Number	Qty Req'd
SHOCK ABSORBER			
Nitro Gas	<i>Height Adjustable Strut</i>	12716GR	2
COIL SPRING			
	Additional Weight		
Performance	<i>0-50kg</i>	NISS040B	1
Constant Load	<i>50-110kg</i>	NISS040C	1
TRIM PACKER			
10mm Spacer	<i>Ironman Struts Only</i>	HILFR10	2
15mm Spacer	<i>Ironman Struts Only</i>	HILFR15	2

REAR SUSPENSION

Product		Part Number	Qty Req'd
SHOCK ABSORBER			
Nitro Gas		12718GR	2
COIL SPRING			
	Additional Weight		
Performance	<i>0-250kg</i>	NISS042B	1
Constant Load	<i>250kg-GVM</i>	NISS042C	1

SUSPENSION KIT

Product	Part Number
Performance with Gas Shocks - <i>Check Front Coil</i>	NISS042BKG
Constant Load with Gas Shocks - <i>Check Front Coil</i>	NISS042CKG

NOTE: Image above indicates kit contents.

**Unnecessary fitment of Trim Packers may lift vehicle too high.
It is also essential to select the correct front coil springs to maintain a minimum of 60mm downward suspension travel.**



NAVARA

D21

1985 - 1996

40mm Lift

FRONT SUSPENSION

Product	Part Number	Qty Req'd
SHOCK ABSORBER		
Nitro Gas	12087GR	2
Foam Cell	24087FE	2
SPRING		
Uprated Torsion Bar	NISS013	1
STEERING DAMPER		
Foam Cell	<i>Equipped Models Only</i>	3535

REAR SUSPENSION

Product	Part Number	Qty Req'd	
SHOCK ABSORBER			
Nitro Gas	<i>Comfort Soft Ride</i>	12636GRC	2
Nitro Gas		12636GR	2
Foam Cell		24636FE	2
LEAF SPRING			
	Additional Weight		
Comfort Drivers Side	0-100kg	NISS014AD/S	1
Comfort Near Side	0-100kg	NISS014AN/S	1
Performance Drivers Side	0-250kg	NISS014BD/S	1
Performance Near Side	0-250kg	NISS014BN/S	1
Constant Load Drivers Side	250kg-GVM	NISS014CD/S	1
Constant Load Near Side	250kg-GVM	NISS014CN/S	1
U-BOLTS			
U-Bolt Kit	788UBK	2	
POLYURETHANE SPRING BUSHES			
Complete Set	704UK	1	
GREASABLE SHACKLES & PINS			
Greasable Shackle	797	2	
Greasable Pin	798	2	

SUSPENSION KIT

Product	Part Number
Comfort with Gas Shocks	NISS014AKG
Comfort with Foam Cell Shocks	NISS014AKF
Performance with Gas Shocks	NISS014BKG
Performance with Foam Cell Shocks	NISS014BKF
Constant Load with Gas Shocks	NISS014CKG
Constant Load with Foam Cell Shocks	NISS014CKF

NOTE: Image above indicates kit contents.

NAVARA

D22

1997 On

40mm Lift



FRONT SUSPENSION

Product	Part Number	Qty Req'd
SHOCK ABSORBER		
Nitro Gas	12791GR	2
SPRING		
Uprated Torsion Bar	NISS025	1

REAR SUSPENSION

Product	Part Number	Qty Req'd	
SHOCK ABSORBER			
Nitro Gas	<i>Comfort Soft Ride</i>	12636GRC	2
Nitro Gas		12636GR	2
LEAF SPRING			
	Additional Weight		
Comfort Drivers Side	0-100kg	NISS014AD/S	1
Comfort Near Side	0-100kg	NISS014AN/S	1
Performance Drivers Side	0-250kg	NISS014BD/S	1
Performance Near Side	0-250kg	NISS014BN/S	1
Constant Load Drivers Side	250kg-GVM	NISS014CD/S	1
Constant Load Near Side	250kg-GVM	NISS014CN/S	1
U-BOLTS			
U-Bolt Kit	788UBK	2	
POLYURETHANE SPRING BUSHES			
Complete Set	704UK	1	
GREASABLE SHACKLES & PINS			
Greasable Shackle	797	2	
Greasable Pin	798	2	

SUSPENSION KIT

Product	Part Number
Comfort with Gas Shocks	NISS025AKG
Performance with Gas Shocks	NISS025BKG
Constant Load with Gas Shocks	NISS025CKG

NOTE: Image above indicates kit contents.

**Upper Control Arm may contact with Front Shock Absorber.
It may be necessary to grind away a small amount of material
from the Control Arm to create more clearance.**



NAVARA
D40
2005 On
40mm Lift

FRONT SUSPENSION

Product		Part Number	Qty Req'd
SHOCK ABSORBER			
Nitro Gas	<i>Height Adjustable Strut</i>	12716GR	2
COIL SPRING			
	Additional Weight		
Performance	<i>0-50kg</i>	NISS040B	1
Constant Load	<i>50-110kg</i>	NISS040C	1
TRIM PACKER			
10mm Spacer	<i>Ironman Struts Only</i>	HILFR10	2
15mm Spacer	<i>Ironman Struts Only</i>	HILFR15	2

REAR SUSPENSION

Product		Part Number	Qty Req'd
SHOCK ABSORBER			
Nitro Gas		12717GR	2
LEAF SPRING			
	Additional Weight		
Performance	<i>0-300kg</i>	NISS041B	2
Constant Load	<i>300kg-GVM</i>	NISS041C	2
U-BOLTS			
U-Bolt Kit		437UBK	2
POLYURETHANE SPRING BUSHES			
Complete Set		769UK	1
GREASABLE SHACKLES & PINS			
Greasable Shackle		797-1	2

SUSPENSION KIT

Product	Part Number
Performance with Gas Shocks - <i>Check Front Coil</i>	NISS041BKG
Constant Load with Gas Shocks - <i>Check Front Coil</i>	NISS041CKG

NOTE: Image above indicates kit contents.

**Unnecessary fitment of Trim Packers may lift vehicle too high.
 It is also essential to select the correct front coil springs to
 maintain a minimum of 60mm downward suspension travel.**

XTRAIL

T30
2001
35mm Lift

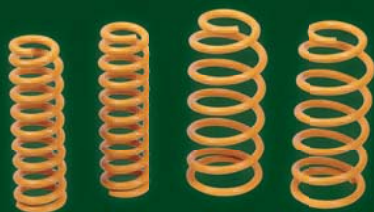

FRONT SUSPENSION

Product	Part Number	Qty Req'd
COIL SPRING		
Performance	NISS038B	1

Additional Weight

0-50kg

REAR SUSPENSION

Product	Part Number	Qty Req'd
COIL SPRING		
Performance	NISS039B	1

Additional Weight

0-200kg



MUSSO
1996 On
40mm Lift

FRONT SUSPENSION

Product	Part Number	Qty Req'd
SHOCK ABSORBER		
Nitro Gas	12667GR	2
Foam Cell	24667FE	2
SPRING		
Upated Torsion Bar	SSANG001	1

REAR SUSPENSION

Product	Part Number	Qty Req'd
COIL SPRING		
Performance	SSANG002B	1
	<i>Additional Weight: 0-200kg</i>	
SHOCK ABSORBER		
Nitro Gas	12661GR*	2
Foam Cell	24661FE*	2

* Please order Part # 895 when ordering (12661GR) (24661FE) Shock Absorbers to convert lower eye in Ssangyong

SUSPENSION KIT

Product	Part Number
Performance with Gas Shocks	SSANG002BKG
Performance with Foam Cell Shocks	SSANG002BKF

NOTE: Image above indicates kit contents.

SIERRA

LJ, SJ

Leaf Springs, 1981 On
50mm Lift**FRONT SUSPENSION**

Product		Part Number	Qty Req'd
SHOCK ABSORBER			
Nitro Gas		12085GR	2
LEAF SPRING			
	Additional Weight		
Performance Drivers Side	0-50kg	SUZ001BD/S	1
Performance Near Side	0-50kg	SUZ001BN/S	1
STEERING DAMPER			
Foam Cell		3530	1
U-BOLTS			
U-Bolt Kit	<i>Drivers Side</i>	654UBK	1
U-Bolt Kit	<i>Near Side</i>	655UBK	1
POLYURETHANE SPRING BUSHES			
Complete Set		734UK	1

REAR SUSPENSION

Product		Part Number	Qty Req'd
SHOCK ABSORBER			
Nitro Gas		12086GR	2
LEAF SPRING			
	Additional Weight		
Performance	0-200kg	SUZ002B	2
U-BOLTS			
U-Bolt Kit		655UBK	2
POLYURETHANE SPRING BUSHES			
Complete Set		734UK	1

SUSPENSION KIT

Product	Part Number
Performance with Gas Shocks	SUZ001BKG

NOTE: Image above indicates kit contents.

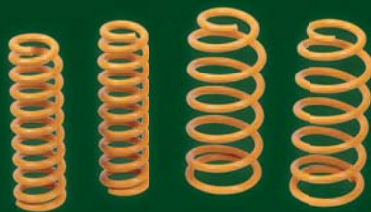

SIERRA
 SJ80
 1997 On
 35mm Lift

FRONT SUSPENSION

Product	Additional Weight	Part Number	Qty Req'd
COIL SPRING			
Performance	0-40kg	SUZ007B	1

REAR SUSPENSION

Product	Additional Weight	Part Number	Qty Req'd
COIL SPRING			
Performance	0-200kg	SUZ008B	1

VITARA
SWB, LWB
1988 On
35mm Lift



FRONT SUSPENSION

Product		Part Number	Qty Req'd
SHOCK ABSORBER			
Nitro Gas	<i>Mini Strut</i>	12083GR	2
COIL SPRING			
	Additional Weight		
SWB Models	<i>0-50kg</i>	SUZ003B	1
LWB Models	<i>0-50kg</i>	SUZ005B	1

REAR SUSPENSION

Product		Part Number	Qty Req'd
SHOCK ABSORBER			
Nitro Gas	<i>SWB Models</i>	12089GR	2
Nitro Gas	<i>LWB Models</i>	12658GR	2
COIL SPRING			
	Additional Weight		
SWB Models	<i>0-200kg</i>	SUZ004B	1
LWB Models	<i>0-200kg</i>	SUZ006B	1

SUSPENSION KIT

Product	Part Number
Performance SWB	SUZ003BKG
Performance LWB	SUZ005BKG

NOTE: Image above indicates kit contents.



GRAND VITARA
SWB, LWB SQ420, 625, XL7
4/1998 - 7/2005
35mm Lift

FRONT SUSPENSION

Product		Part Number	Qty Req'd
SHOCK ABSORBER			
Nitro Gas	<i>Mini Strut</i>	12083GR	2
COIL SPRING			
	Additional Weight		
SWB / 4 Cyl Carburetor	0-50kg	SUZ005B	1
V6 / 4 Cyl Fuel Injected	0-50kg	SUZ015B	1
XL7	0-50kg	SUZ017B	1

REAR SUSPENSION

Product		Part Number	Qty Req'd
SHOCK ABSORBER			
Nitro Gas		12658GR	2
COIL SPRING			
	Additional Weight		
SWB Models	0-200kg	SUZ013B	1
LWB Models	0-200kg	SUZ016B	1
XL7 Models	0-200kg	SUZ018B	1

SUSPENSION KIT

Product	Part Number
Performance SWB / 4 Cyl Carburetor	SUZ013BKG
Performance LWB / V6 / 4 Cyl Fuel Injected	SUZ016BKG
Performance XL7	SUZ018BKG

NOTE: Image above indicates kit contents.

GRAND VITARA8/2005 On
35mm Lift**FRONT SUSPENSION**

Product		Part Number	Qty Req'd
COIL SPRING	Additional Weight		
Petrol 4 Cyl	0-50kg	SUZ019B	1
Petrol V6 / Diesel	0-50kg	SUZ019C	1
SHOCK ABSORBER			
Nitro Gas	Mini Strut	12721GR	2

REAR SUSPENSION

Product		Part Number	Qty Req'd
COIL SPRING	Additional Weight		
Performance	0-200kg	SUZ020B	1
SHOCK ABSORBER			
Nitro Gas		12722GR	2

NOTE: Image above indicates kit contents.

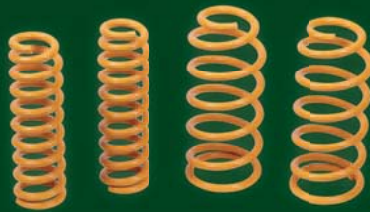

FORESTER
SF5, GX, RX, GT
35mm Lift

FRONT SUSPENSION

Product	Part Number	Qty Req'd
COIL SPRING	Additional Weight	
Performance 1997 - 2001	0-50kg	SUB001B
Performance 2002 On	0-50kg	SUB003B

REAR SUSPENSION

Product	Part Number	Qty Req'd
COIL SPRING	Additional Weight	
Performance 1997 - 2001	0-200kg	SUB002B
Performance 2002 On	0-200kg	SUB004B*

* Not suitable for Self Levelling Suspension Models..

HILUX

LN/RN 46

Solid Front Axle, 1979 - 10/1983

50mm Lift

**FRONT SUSPENSION**

Product		Part Number	Qty Req'd
SHOCK ABSORBER			
Nitro Gas	<i>Comfort Soft Ride</i>	12639GRC	2
Nitro Gas		12639GR	2
Foam Cell		24639FE	2
LEAF SPRING			
	Additional Weight		
Petrol Drivers Side	<i>0-50kg</i>	TOY010BD/S	1
Petrol Near Side	<i>0-50kg</i>	TOY010BN/S	1
Diesel Drivers Side	<i>0-100kg</i>	TOY010CD/S	1
Diesel Near Side	<i>0-100kg</i>	TOY010CN/S	1
STEERING DAMPER			
Foam Cell		3521	1
U-BOLTS			
U-Bolt Kit	<i>Drivers Side</i>	678UBK	1
U-Bolt Kit	<i>Near Side</i>	437UBK	1
POLYURETHANE SPRING BUSHES			
Complete Set		732UK	1
GREASABLE SHACKLES & PINS			
Greasable Shackle		384	2
Greasable Pin		385	2
REAR SUSPENSION			
Product		Part Number	Qty Req'd
SHOCK ABSORBER			
Nitro Gas	<i>Comfort Soft Ride</i>	12636GRC	2
Nitro Gas		12636GR	2
Foam Cell		24636FE	2
LEAF SPRING			
	Additional Weight		
Performance	<i>0-300kg</i>	TOY011B	2
Constant Load	<i>300kg-GVM</i>	TOY011C	2
U-BOLTS			
U-Bolt Kit		437UBK	2
POLYURETHANE SPRING BUSHES			
Complete Set		733UK	1
GREASABLE SHACKLES & PINS			
Greasable Shackle	<i>Straight Shackle</i>	386	2
Greasable Shackle	<i>Straight Shackle Extended 5mm</i>	386-2	2
Greasable Pin		385	2
SUSPENSION KIT			
Product		Part Number	
Performance with Gas Shocks		TOY010BKG1	
Performance with Foam Cell Shocks		TOY010BKF1	
Constant Load with Gas Shocks		TOY010CKG1	
Constant Load with Foam Cell Shocks		TOY010CKF1	

NOTE: Image above indicates kit contents.



FRONT SUSPENSION

Product	Part Number	Qty Req'd
---------	-------------	-----------

SHOCK ABSORBER

Nitro Gas	<i>Comfort Soft Ride</i>	12639GRC	2
Nitro Gas		12639GR	2
Foam Cell		24639FE	2

LEAF SPRING **Additional Weight**

Petrol Drivers Side	<i>0-50kg</i>	TOY010BD/S	1
Petrol Near Side	<i>0-50kg</i>	TOY010BN/S	1
Diesel Drivers Side	<i>0-100kg</i>	TOY010CD/S	1
Diesel Near Side	<i>0-100kg</i>	TOY010CN/S	1

STEERING DAMPER

Foam Cell		3521	1
-----------	--	------	---

U-BOLTS

U-Bolt Kit	<i>Drivers Side</i>	678UBK	1
U-Bolt Kit	<i>Near Side</i>	437UBK	1

POLYURETHANE SPRING BUSHES

Complete Set		732UK	1
--------------	--	-------	---

GREASABLE SHACKLES & PINS

Greasable Shackle		384	2
Greasable Pin		385	2

REAR SUSPENSION

Product	Part Number	Qty Req'd
---------	-------------	-----------

SHOCK ABSORBER

Nitro Gas	<i>Comfort Soft Ride</i>	12650GRC	2
Nitro Gas		12650GR	2
Foam Cell		24650FE	2

LEAF SPRING **Additional Weight**

Performance	<i>0-300kg</i>	TOY011B	2
Constant Load	<i>300kg-GVM</i>	TOY011C	2

U-BOLTS

U-Bolt Kit		437UBK	2
------------	--	--------	---

POLYURETHANE SPRING BUSHES

Complete Set		733UK	1
--------------	--	-------	---

GREASABLE SHACKLES & PINS

Greasable Shackle	<i>Straight Shackle</i>	386	2
Greasable Shackle	<i>Straight Shackle Extended 5mm</i>	386-2	2
Greasable Pin		385	2

SUSPENSION KIT

Product	Part Number
---------	-------------

Performance with Gas Shocks	TOY010BKG2
Performance with Foam Cell Shocks	TOY010BKF2
Constant Load with Gas Shocks	TOY010CKG2
Constant Load with Foam Cell Shocks	TOY010CKF2

NOTE: Image above indicates kit contents.

HILUX

4RUNNER, LN61, YN63

1988 - 1997

45mm Lift

**FRONT SUSPENSION**

Product	Part Number	Qty Req'd
SHOCK ABSORBER		
Nitro Gas	12088GR	2
Foam Cell	24088FE	2
SPRING		
Up-rated Torsion Bar	TOY026	1
STEERING DAMPER		
Foam Cell	3533	1

REAR SUSPENSION

Product	Part Number	Qty Req'd	
SHOCK ABSORBER			
Nitro Gas	<i>Comfort Soft Ride</i>	12650GRC	2
Nitro Gas		12650GR	2
Foam Cell		24650FE	2
LEAF SPRING			
	Additional Weight		
Performance	<i>0-300kg</i>	TOY011B	2
Constant Load	<i>300kg-GVM</i>	TOY011C	2
U-BOLTS			
U-Bolt Kit	437UBK	2	
POLYURETHANE SPRING BUSHES			
Complete Set	733UK	1	
GREASABLE SHACKLES & PINS			
Greasable Shackle	<i>Straight Shackle</i>	386	2
Greasable Shackle	<i>Straight Shackle Extended 5mm</i>	386-2	2
Greasable Pin		385	2

SUSPENSION KIT

Product	Part Number
Performance with Gas Shocks	TOY011BKG
Performance with Foam Cell Shocks	TOY011BKF
Constant Load with Gas Shocks	TOY011CKG
Constant Load with Foam Cell Shocks	TOY011CKF

NOTE: Image above indicates kit contents.



HILUX
SURF / LN/RN/YN/VZN 130 V6
 1988 - 1997
 45mm Lift

FRONT SUSPENSION

Product	Part Number	Qty Req'd
SHOCK ABSORBER		
Nitro Gas	12088GR	2
Foam Cell	24088FE	2
SPRING		
Uprated Torsion Bar	TOY026	1
STEERING DAMPER		
Foam Cell	3533	1

REAR SUSPENSION

Product	Part Number	Qty Req'd
SHOCK ABSORBER		
Nitro Gas	<i>Comfort Soft Ride</i> 12637GRC	2
Nitro Gas	12637GR	2
Foam Cell	24637FE	2
COIL SPRING		
Performance	<i>0-200kg</i> TOY023B	1
Constant Load	<i>200kg-GVM</i> TOY023C	1

SUSPENSION KIT

Product	Part Number
Performance with Gas Shocks	TOY023BKG
Performance with Foam Cell Shocks	TOY023BKF
Constant Load with Gas Shocks	TOY023CKG
Constant Load with Foam Cell Shocks	TOY023CKF

NOTE: Image above indicates kit contents.

HILUX

LN/RN 107,108,110,111,167

Pre 3/2005

40mm Lift

**FRONT SUSPENSION**

Product	Part Number	Qty Req'd
SHOCK ABSORBER		
Nitro Gas	12088GR	2
Foam Cell	24088FE	2
SPRING		
Up-rated Torsion Bar	TOY026	1
STEERING DAMPER		
Foam Cell	3533	1

REAR SUSPENSION

Product	Part Number	Qty Req'd	
SHOCK ABSORBER			
Nitro Gas	<i>Comfort Soft Ride</i>	12081GRC	2
Nitro Gas		12081GR	2
Foam Cell		24081FE	2
LEAF SPRING			
	Additional Weight		
Comfort	0-100kg	TOY027A	2
Performance	0-200kg	TOY027B	2
Constant Load	200kg-GVM	TOY027C	2
U-BOLTS			
U-Bolt Kit		437UBK	2
U-Bolt Kit	<i>Suit TOY027A Spring</i>	678UBK	2
POLYURETHANE SPRING BUSHES			
Complete Set		758UK	1
GREASABLE SHACKLES & PINS			
Greasable Shackle	<i>Stepped Shackle</i>	386-1	2
Non Greasable Pin		387-1	2

SUSPENSION KIT

Product	Part Number
Comfort with Gas Shocks	TOY027AKG
Comfort with Foam Cell Shocks	TOY027AKF
Performance with Gas Shocks	TOY027BKG
Performance with Foam Cell Shocks	TOY027BKF
Constant Load with Gas Shocks	TOY027CKG
Constant Load with Foam Cell Shocks	TOY027CKF

NOTE: Image above indicates kit contents.



HILUX / VIGO
GGN25R KUN26R
 3/2005 On
 45mm Lift

FRONT SUSPENSION

Product		Part Number	Qty Req'd
SHOCK ABSORBER			
Nitro Gas	<i>Height Adjustable Strut</i>	12710GR	2
COIL SPRING			
	Additional Weight		
Performance	<i>0-50kg</i>	TOY055B	1
Constant Load	<i>50-100kg</i>	TOY055C	1
TRIM PACKER			
10mm Spacer	<i>Ironman Struts Only</i>	HILFR10	2
15mm Spacer	<i>Ironman Struts Only</i>	HILFR15	2

REAR SUSPENSION

Product		Part Number	Qty Req'd
SHOCK ABSORBER			
Nitro Gas	<i>Comfort Soft Ride</i>	12650GRC	2
Nitro Gas		12650GR	2
LEAF SPRING			
	Additional Weight		
Comfort	<i>0-100kg</i>	TOY057A	2
Performance	<i>0-200kg</i>	TOY057B	2
Constant Load	<i>200kg-GVM</i>	TOY057C	2
U-BOLTS			
U-Bolt Kit		437UBK	2
U-Bolt Kit	<i>Suit TOY057A Spring</i>	678UBK	2
POLYURETHANE SPRING BUSHES			
Complete Set		767UK	1
GREASABLE SHACKLES & PINS			
Greasable Shackle		386-3	2
Non Greasable Pin		387-1	2

SUSPENSION KIT

Product	Part Number
Comfort with Gas Shocks - <i>Check Front Coil</i>	TOY057AKG
Performance with Gas Shocks - <i>Check Front Coil</i>	TOY057BKG
Constant Load with Gas Shocks - <i>Check Front Coil</i>	TOY057CKG

NOTE: Image above indicates kit contents.

**Unnecessary fitment of Trim Packers may lift vehicle too high.
 It is also essential to select the correct front coil springs to
 maintain a minimum of 60mm downward suspension travel.**

LANDCRUISER

40 SERIES

1960 - 1980

50mm Lift

**FRONT SUSPENSION**

Product		Part Number	Qty Req'd
SHOCK ABSORBER			
Nitro Gas	<i>Comfort Soft Ride</i>	12635GRC	2
Nitro Gas		12635GR	2
Foam Cell		24635FE	2
LEAF SPRING			
	Additional Weight		
Performance	<i>0-100kg</i>	TOY001B	2
STEERING DAMPER			
Foam Cell		3523	1
U-BOLTS			
U-Bolt Kit		415UBK	2
POLYURETHANE SPRING BUSHES			
Complete Set		713UK	1
GREASABLE SHACKLES & PINS			
Greasable Shackle	<i>Left Side</i>	343LH	1
Greasable Shackle	<i>Right Side</i>	343RH	1
Greasable Pin		346	2

REAR SUSPENSION

Product		Part Number	Qty Req'd
SHOCK ABSORBER			
Nitro Gas	<i>Comfort Soft Ride</i>	12636GRC	2
Nitro Gas		12636GR	2
Foam Cell		24636FE	2
LEAF SPRING			
	Additional Weight		
Performance	<i>0-200kg</i>	TOY002B	2
U-BOLTS			
U-Bolt Kit		415UBK	2
POLYURETHANE SPRING BUSHES			
Complete Set		713UK	1
GREASABLE SHACKLES & PINS			
Greasable Shackle	<i>Right Side</i>	343LH	1
Greasable Shackle	<i>Left Side</i>	343RH	1
Greasable Pin		346	2

SUSPENSION KIT

Product	Part Number
Performance with Gas Shocks	TOY001BKG
Performance with Foam Cell Shocks	TOY001BKF

NOTE: Image above indicates kit contents.



LANDCRUISER
 40, 42, 46 SERIES
 1980 - 1984
 50mm Lift

FRONT SUSPENSION

Product		Part Number	Qty Req'd
SHOCK ABSORBER			
Nitro Gas	<i>Comfort Soft Ride</i>	12635GRC	2
Nitro Gas		12635GR	2
Foam Cell		24635FE	2
LEAF SPRING			
	Additional Weight		
Performance	<i>0-80kg</i>	TOY004B	2
Constant Load	<i>80-120kg</i>	TOY004C	2
STEERING DAMPER			
Foam Cell		3523	1
U-BOLTS			
U-Bolt Kit		415UBK	2
POLYURETHANE SPRING BUSHES			
Complete Set		719UK	1
GREASABLE SHACKLES & PINS			
Greasable Shackle	<i>Left Side</i>	348LH	1
Greasable Shackle	<i>Right Side</i>	348RH	1
Greasable Pin		351	2

REAR SUSPENSION

Product		Part Number	Qty Req'd
SHOCK ABSORBER			
Nitro Gas	<i>Comfort Soft Ride</i>	12636GRC	2
Nitro Gas		12636GR	2
Foam Cell		24636FE	2
LEAF SPRING			
	Additional Weight		
Performance	<i>0-200kg</i>	TOY034B	2
U-BOLTS			
U-Bolt Kit		415UBK	2
POLYURETHANE SPRING BUSHES			
Complete Set		719UK	1
GREASABLE SHACKLES & PINS			
Greasable Shackle	<i>Right Side</i>	348LH	1
Greasable Shackle	<i>Left Side</i>	348RH	1
Greasable Pin		351	2

SUSPENSION KIT

Product	Part Number
Performance with Gas Shocks	TOY004BKG
Performance with Foam Cell Shocks	TOY004BKF

NOTE: Image above indicates kit contents.

LANDCRUISER

45 SERIES

Pre 7/1980

50mm Lift

**FRONT SUSPENSION**

Product		Part Number	Qty Req'd
SHOCK ABSORBER			
Nitro Gas	<i>Comfort Soft Ride</i>	12635GRC	2
Nitro Gas		12635GR	2
Foam Cell		24635FE	2
LEAF SPRING			
	Additional Weight		
Performance	<i>0-100kg</i>	TOY001B	2
STEERING DAMPER			
Foam Cell		3523	1
U-BOLTS			
U-Bolt Kit		415UBK	2
POLYURETHANE SPRING BUSHES			
Complete Set		713UK	1
GREASABLE SHACKLES & PINS			
Greasable Shackle	<i>Left Side</i>	343LH	1
Greasable Shackle	<i>Right Side</i>	343RH	1
Greasable Pin		346	2

REAR SUSPENSION

Product		Part Number	Qty Req'd
SHOCK ABSORBER			
Nitro Gas	<i>Comfort Soft Ride</i>	12636GRC	2
Nitro Gas		12636GR	2
Foam Cell		24636FE	2
LEAF SPRING			
	Additional Weight		
Constant Load	<i>0-400kg</i>	TOY003C	2
U-BOLTS			
U-Bolt Kit		415UBK	2
POLYURETHANE SPRING BUSHES			
Complete Set		714UK	1
GREASABLE SHACKLES & PINS			
Greasable Shackle	<i>Left Side</i>	344	1
Greasable Shackle	<i>Right Side</i>	345	1
Greasable Pin		347	2

SUSPENSION KIT

Product	Part Number
Performance with Gas Shocks	TOY003BKG
Performance with Foam Cell Shocks	TOY003BKF

NOTE: Image above indicates kit contents.



LANDCRUISER
45 / 47 SERIES
 8/1980 - 1985
 50mm Lift

FRONT SUSPENSION

Product		Part Number	Qty Req'd
SHOCK ABSORBER			
Nitro Gas	<i>Comfort Soft Ride</i>	12635GRC	2
Nitro Gas		12635GR	2
Foam Cell		24635FE	2
LEAF SPRING			
	Additional Weight		
Performance	<i>0-80kg</i>	TOY004B	2
Constant Load	<i>80-120kg</i>	TOY004C	2
STEERING DAMPER			
Foam Cell		3523	1
U-BOLTS			
U-Bolt Kit	<i>Drivers Side</i>	449UBK	1
U-Bolt Kit	<i>Passenger Side</i>	415UBK	1
POLYURETHANE SPRING BUSHES			
Complete Set		719UK	1
GREASABLE SHACKLES & PINS			
Greasable Shackle	<i>Left Side</i>	348LH	1
Greasable Shackle	<i>Right Side</i>	348RH	1
Greasable Pin		351	2

REAR SUSPENSION

Product		Part Number	Qty Req'd
SHOCK ABSORBER			
Nitro Gas	<i>Comfort Soft Ride</i>	12636GRC	2
Nitro Gas		12636GR	2
Foam Cell		24636FE	2
LEAF SPRING			
	Additional Weight		
Constant Load	<i>0-400kg</i>	TOY005C	2
U-BOLTS			
U-Bolt Kit		415UBK	2
POLYURETHANE SPRING BUSHES			
Complete Set		719UK	1
GREASABLE SHACKLES & PINS			
Greasable Shackle	<i>Left Side</i>	353LH	1
Greasable Shackle	<i>Right Side</i>	353RH	1
Greasable Pin		351	2

SUSPENSION KIT

Product	Part Number
Performance with Gas Shocks	TOY005BKG
Performance with Foam Cell Shocks	TOY005BKF

NOTE: Image above indicates kit contents.

LANDCRUISER

60, 61 SERIES

Pre 1986

50mm Lift

**FRONT SUSPENSION**

Product		Part Number	Qty Req'd
SHOCK ABSORBER			
Nitro Gas	<i>Comfort Soft Ride</i>	12637GRC	2
Nitro Gas		12637GR	2
Foam Cell		24637FE	2
LEAF SPRING			
	Additional Weight		
Petrol No Accessories	<i>0-50kg</i>	TOY006B	2
Diesel or Accessories	<i>50-100kg</i>	TOY006C	2
Turbo Diesel / Sahara	<i>50-100kg</i>	TOY006D	2
STEERING DAMPER			
Foam Cell		3524	1
U-BOLTS			
U-Bolt Kit		436UBK	2
POLYURETHANE SPRING BUSHES			
Complete Set		719UK	1
GREASABLE SHACKLES & PINS			
Greasable Shackle	<i>Left Side</i>	348LH	1
Greasable Shackle	<i>Right Side</i>	348RH	1
Greasable Pin		351	2

REAR SUSPENSION

Product		Part Number	Qty Req'd
SHOCK ABSORBER			
Nitro Gas	<i>Comfort Soft Ride</i>	12636GRC	2
Nitro Gas		12636GR	2
Foam Cell		24636FE	2
LEAF SPRING			
	Additional Weight		
Performance Drivers Side	<i>0-200kg</i>	TOY007BD/S	1
Performance Near Side	<i>0-200kg</i>	TOY007BN/S	1
Constant Load Drivers Side	<i>200kg-GVM</i>	TOY007CD/S	1
Constant Load Near Side	<i>200kg-GVM</i>	TOY007CN/S	1
U-BOLTS			
U-Bolt Kit		415UBK	2
POLYURETHANE SPRING BUSHES			
Complete Set		719UK	1
GREASABLE SHACKLES & PINS			
Greasable Shackle	<i>Left Side</i>	353LH	1
Greasable Shackle	<i>Right Side</i>	353RH	1
Greasable Pin		351	2

SUSPENSION KIT

Product	Part Number
Performance Petrol with Gas Shocks	TOY006BKG1
Performance Petrol with Foam Cell Shocks	TOY006BKF1
Performance Diesel with Gas Shocks	TOY006CKG1
Performance Diesel with Foam Cell Shocks	TOY006CKF1
Constant Load Petrol with Gas Shocks	TOY007BKG1
Constant Load Petrol with Foam Cell Shocks	TOY007BKF1
Constant Load Diesel with Gas Shocks	TOY007CKG1
Constant Load Diesel with Foam Cell Shocks	TOY007CKF1



LANDCRUISER

60, 61, 62 SERIES

1986 On

50mm Lift

FRONT SUSPENSION

Product		Part Number	Qty Req'd
SHOCK ABSORBER			
Nitro Gas	<i>Comfort Soft Ride</i>	12637GRC	2
Nitro Gas		12637GR	2
Foam Cell		24637FE	2
LEAF SPRING			
	Additional Weight		
Petrol No Accessories	<i>0-50kg</i>	TOY006B	2
Diesel or Accessories	<i>50-100kg</i>	TOY006C	2
Turbo Diesel / Sahara	<i>50-100kg</i>	TOY006D	2
STEERING DAMPER			
Foam Cell		3524	1
U-BOLTS			
U-Bolt Kit		436UBK	2
POLYURETHANE SPRING BUSHES			
Complete Set		719UK	1
GREASABLE SHACKLES & PINS			
Greasable Shackle	<i>Left Side</i>	348LH	1
Greasable Shackle	<i>Right Side</i>	348RH	1
Greasable Pin		351	2

REAR SUSPENSION

Product		Part Number	Qty Req'd
SHOCK ABSORBER			
Nitro Gas	<i>Comfort Soft Ride</i>	12650GRC	2
Nitro Gas		12650GR	2
Foam Cell		24650FE	2
LEAF SPRING			
	Additional Weight		
Performance Drivers Side	<i>0-200kg</i>	TOY007BD/S	1
Performance Near Side	<i>0-200kg</i>	TOY007BN/S	1
Constant Load Drivers Side	<i>200kg-GVM</i>	TOY007CD/S	1
Constant Load Near Side	<i>200kg-GVM</i>	TOY007CN/S	1
U-BOLTS			
U-Bolt Kit		415UBK	2
POLYURETHANE SPRING BUSHES			
Complete Set		719UK	1
GREASABLE SHACKLES & PINS			
Greasable Shackle	<i>Left Side</i>	353LH	1
Greasable Shackle	<i>Right Side</i>	353RH	1
Greasable Pin		351	2

SUSPENSION KIT

Product	Part Number
Performance Petrol with Gas Shocks	TOY006BKG2
Performance Petrol with Foam Cell Shocks	TOY006BKF2
Performance Diesel with Gas Shocks	TOY006CKG2
Performance Diesel with Foam Cell Shocks	TOY006CKF2
Constant Load Petrol with Gas Shocks	TOY007BKG2
Constant Load Petrol with Foam Cell Shocks	TOY007BKF2
Constant Load Diesel with Gas Shocks	TOY007CKG2
Constant Load Diesel with Foam Cell Shocks	TOY007CKF2

NOTE: Barn Door Models may require (D/S-D/S) or (N/S-N/S) Rear Springs.

LANDCRUISER

HZJ, PZJ 70, 73, BJ FJ 70, 73, 74

1984 - 1998

50mm Lift

**FRONT SUSPENSION**

Product		Part Number	Qty Req'd
SHOCK ABSORBER			
Nitro Gas	<i>Comfort Soft Ride</i>	12637GRC	2
Nitro Gas		12637GR	2
Foam Cell		24637FE	2
LEAF SPRING			
	Additional Weight		
Performance	<i>0-100kg</i>	TOY008B	2
STEERING DAMPER			
Foam Cell		3524	1
U-BOLTS			
U-Bolt Kit		436UBK	2
POLYURETHANE SPRING BUSHES			
Complete Set		719UK	1
GREASABLE SHACKLES & PINS			
Greasable Shackle	<i>Left Side</i>	348LH	1
Greasable Shackle	<i>Right Side</i>	348RH	1
Greasable Pin		351	2

REAR SUSPENSION

Product		Part Number	Qty Req'd
SHOCK ABSORBER			
Nitro Gas	<i>Comfort Soft Ride</i>	12650GRC	2
Nitro Gas		12650GR	2
Foam Cell		24650FE	2
LEAF SPRING			
	Additional Weight		
Performance	<i>0-200kg</i>	TOY007AN/S	2
Constant Load	<i>200-400kg</i>	TOY007BN/S	2
U-BOLTS			
U-Bolt Kit		415UBK	2
POLYURETHANE SPRING BUSHES			
Complete Set		719UK	1
GREASABLE SHACKLES & PINS			
Greasable Shackle	<i>Left Side</i>	353LH	1
Greasable Shackle	<i>Right Side</i>	353RH	1
Greasable Pin		354	2

SUSPENSION KIT

Product	Part Number
Comfort with Gas Shocks	TOY016AKG
Comfort with Foam Cell Shocks	TOY016AKF
Performance with Gas Shocks	TOY016BKG
Performance with Foam Cell Shocks	TOY016BKF

NOTE: Image above indicates kit contents.



LANDCRUISER
BUNDERA LJ RJ 70, 73
 1984 - 1989
 50mm Lift

FRONT SUSPENSION

Product	Part Number	Qty Req'd	
SHOCK ABSORBER			
Nitro Gas	12091GR	2	
Foam Cell	24091FE	2	
COIL SPRING			
Performance	Additional Weight 0-50kg	TOY018B	1
STEERING DAMPER			
Foam Cell	3524	1	

REAR SUSPENSION

Product	Part Number	Qty Req'd	
SHOCK ABSORBER			
Nitro Gas	<i>Left Side</i>	12639GR*	1
Foam Cell	<i>Left Side</i>	24639FE*	1
Nitro Gas	<i>Right Side</i>	12650GR	1
Foam Cell	<i>Right Side</i>	24650FE	1
* Please order x2 Part # 630 when ordering (12639GR) (24639FE) Shock Absorbers to convert lower eye in Bundera			
COIL SPRING			
Performance	Additional Weight 0-150kg	TOY019B	1

SUSPENSION KIT

Product	Part Number
Performance with Gas Shocks	TOY018BKG
Performance with Foam Cell Shocks	TOY018BKF

NOTE: Image above indicates kit contents.

LANDCRUISER

KZJ 70, 73

1990 - 1996

50mm Lift

**FRONT SUSPENSION**

Product	Part Number	Qty Req'd
SHOCK ABSORBER		
Nitro Gas	12696GR	2
Foam Cell	24696FE	2
COIL SPRING		
	Additional Weight	
Performance	0-50kg	TOY048B
STEERING DAMPER		
Foam Cell	3524	1

REAR SUSPENSION

Product	Part Number	Qty Req'd
SHOCK ABSORBER		
Nitro Gas	12697GR	2
Foam Cell	24697FE	2
COIL SPRING		
	Additional Weight	
Performance	0-150kg	TOY049B

SUSPENSION KIT

Product	Part Number
Performance with Gas Shocks	TOY048BKG
Performance with Foam Cell Shocks	TOY048BKF

NOTE: Image above indicates kit contents.



**LANDCRUISER
71 SERIES**

50mm Lift

FRONT SUSPENSION

Product		Part Number	Qty Req'd
SHOCK ABSORBER			
Nitro Gas		12091GR	2
Foam Cell		24091FE	2
Foam Cell	<i>Extra Long Travel</i>	24091LFE	2
COIL SPRING			
	Additional Weight		
Performance	<i>0-50kg</i>	TOY046B	1
Constant Load	<i>50-110kg</i>	TOY046C	1
STEERING DAMPER			
Foam Cell		3524	1
OFFSET CASTER BUSH KIT			
Adjustable Offset Bush Kit	<i>STD, 2.5 Degree, 3.5 Degree</i>	1144	1
Offset Bush Kit	<i>2 Degree</i>	1144SK	1

REAR SUSPENSION

Product		Part Number	Qty Req'd
SHOCK ABSORBER			
Nitro Gas		12081GR	2
Foam Cell		24081FE	2
Foam Cell	<i>Extra Long Travel</i>	24094FE	2
LEAF SPRING			
	Additional Weight		
Comfort	<i>0-150kg</i>	TOY007AD/S	2
Performance	<i>0-250kg</i>	TOY007BD/S	2
Constant Load	<i>250kg-GVM</i>	TOY007CD/S	2
U-BOLTS			
U-Bolt Kit		415UBK	2
POLYURETHANE SPRING BUSHES			
Complete Set		1185UK	1
GREASABLE SHACKLES & PINS			
Greasable Shackle	<i>Must Use Ironman Bushes</i>	1141-1	2
Greasable Pin	<i>Must Use Ironman Bushes</i>	1142	2

SUSPENSION KIT

Product	Part Number
Comfort with Gas Shocks	TOY058AKG
Comfort with Foam Cell Shocks	TOY058AKF
Performance with Gas Shocks	TOY058BKG
Performance with Foam Cell Shocks	TOY058BKF
Constant Load with Gas Shocks	TOY058CKG
Constant Load with Foam Cell Shocks	TOY058CKF

NOTE: Image above indicates kit contents.

LANDCRUISER

75 SERIES

1984 - 1999

50mm Lift

**FRONT SUSPENSION**

Product	Part Number	Qty Req'd
---------	-------------	-----------

SHOCK ABSORBER

Nitro Gas	<i>Comfort Soft Ride</i>	12637GRC	2
Nitro Gas		12637GR	2
Foam Cell		24637FE	2

LEAF SPRING**Additional Weight**

Petrol no Accessories	<i>0-50kg</i>	TOY008B	2
Diesel or Accessories	<i>50-110kg</i>	TOY008C	2

STEERING DAMPER

Foam Cell		3524	1
-----------	--	------	---

U-BOLTS

U-Bolt Kit		436UBK	2
------------	--	--------	---

POLYURETHANE SPRING BUSHES

Complete Set		719UK	1
--------------	--	-------	---

GREASABLE SHACKLES & PINS

Greasable Shackle	<i>Left Side</i>	348LH	1
Greasable Shackle	<i>Right Side</i>	348RH	1
Greasable Pin		351	2

REAR SUSPENSION

Product	Part Number	Qty Req'd
---------	-------------	-----------

SHOCK ABSORBER

Nitro Gas	<i>Comfort Soft Ride</i>	12081GRC	2
Nitro Gas		12081GR	2
Foam Cell		24081FE	2
Foam Cell	<i>Extra Long Travel</i>	24094FE	2

LEAF SPRING**Additional Weight**

Performance	<i>0-200kg</i>	TOY009B	2
Constant Load	<i>200-400kg</i>	TOY009C	2
Mining	<i>400-600kg</i>	TOY009D	2
Extra Load Mining	<i>600kg-GVM</i>	TOY009E	2

U-BOLTS

U-Bolt Kit		416UBK	2
------------	--	--------	---

POLYURETHANE SPRING BUSHES

Complete Set		720UK	1
--------------	--	-------	---

GREASABLE SHACKLES & PINS

Greasable Shackle	<i>Left Side</i>	353LH	1
Greasable Shackle	<i>Right Side</i>	353RH	1
Greasable Pin		354	2

SUSPENSION KIT

Product	Part Number
---------	-------------

Performance with Gas Shocks	TOY008BKG
Performance with Foam Cell Shocks	TOY008BKF
Constant Load with Gas Shocks	TOY008CKG
Constant Load with Foam Cell Shocks	TOY008CKF
Mining with Gas Shocks	TOY009DKG
Mining with Foam Cell Shocks	TOY009DKF
Extra Mining with Gas Shocks	TOY009EKG
Extra Mining with Foam Cell Shocks	TOY009EKF

NOTE: Image above indicates kit contents.



LANDCRUISER
76 SERIES WAGON
 2007 On
 50mm Lift

FRONT SUSPENSION

Product		Part Number	Qty Req'd
SHOCK ABSORBER			
Nitro Gas		12091GR	2
Foam Cell		24091FE	2
COIL SPRING			
	Additional Weight		
Performance	0-50kg	TOY046B	1
Constant Load	50-110kg	TOY046C	1
STEERING DAMPER			
Foam Cell		3525	1
OFFSET CASTER BUSH KIT			
Adjustable Offset Bush Kit	STD, 2.5 Degree, 3.5 Degree	1144	1
Offset Bush Kit	2 Degree	1144SK	1

REAR SUSPENSION

Product		Part Number	Qty Req'd
SHOCK ABSORBER			
Nitro Gas		12094GR	2
Foam Cell		24094FE	2
LEAF SPRING			
	Additional Weight		
Performance	0-300kg	TOY062B	2
Constant Load	300kg-GVM	TOY062C	2
U-BOLTS			
U-Bolt Kit		416UBK	2
POLYURETHANE SPRING BUSHES			
Complete Set		1085UK	1
GREASABLE SHACKLES & PINS			
Greasable Shackle	Must Use Ironman Bushes	1141-1	2
Greasable Pin	Must Use Ironman Bushes	1142	2

SUSPENSION KIT

Product	Part Number
Performance with Gas Shocks	TOY062BKG
Performance with Foam Cell Shocks	TOY062BKF
Constant Load with Gas Shocks	TOY062CKG
Constant Load with Foam Cell Shocks	TOY062CKF

NOTE: Image above indicates kit contents.

LANDCRUISER

78 SERIES TROOP CARRIER

1999 On
50mm Lift



FRONT SUSPENSION

Product		Part Number	Qty Req'd
SHOCK ABSORBER			
Nitro Gas		12091GR	2
Foam Cell		24091FE	2
COIL SPRING			
	Additional Weight		
Performance	0-50kg	TOY046B	1
Constant Load	50-110kg	TOY046C	1
STEERING DAMPER			
Foam Cell	1999-2006	3524	1
Foam Cell	2007 On	3525	1
OFFSET CASTER BUSH KIT			
Adjustable Offset Bush Kit	STD, 2.5 Degree, 3.5 Degree	1144	1
Offset Bush Kit	2 Degree	1144SK	1

REAR SUSPENSION

Product		Part Number	Qty Req'd
SHOCK ABSORBER			
Nitro Gas		12094GR	2
Foam Cell		24094FE	2
Foam Cell	Extra Long Travel	24094LFE	2
LEAF SPRING			
	Additional Weight		
Comfort	0-150kg	TOY047A	2
Performance	0-250kg	TOY047B	2
Constant Load	250-400kg	TOY047C	2
Mining	400kg-GVM	TOY047D	2
U-BOLTS			
U-Bolt Kit		416UBK	2
POLYURETHANE SPRING BUSHES			
Complete Set		1084UK	1
GREASABLE SHACKLES & PINS			
Greasable Shackle	Must Use Ironman Bushes	1141	2
Greasable Pin	Must Use Ironman Bushes	1142	2

SUSPENSION KIT

Product	Part Number
Comfort with Gas Shocks	TOY046AKG
Comfort with Foam Cell Shocks	TOY046AKF
Performance with Gas Shocks	TOY046BKG
Performance with Foam Cell Shocks	TOY046BKF
Constant Load with Gas Shocks	TOY046CKG
Constant Load with Foam Cell Shocks	TOY046CKF
Mining with Gas Shocks	TOY046DKG
Mining with Foam Cell Shocks	TOY046DKF

NOTE: Image above indicates kit contents.



LANDCRUISER
79 SERIES TRAYBACK
 1999 On
 50mm Lift

FRONT SUSPENSION

Product		Part Number	Qty Req'd
SHOCK ABSORBER			
Nitro Gas		12091GR	2
Foam Cell		24091FE	2
COIL SPRING		Additional Weight	
Performance	0-50kg	TOY046B	1
Constant Load	50-110kg	TOY046C	1
STEERING DAMPER			
Foam Cell	1999-2006	3524	1
Foam Cell	2007 On	3525	1
OFFSET CASTER BUSH KIT			
Adjustable Offset Bush Kit	STD, 2.5 Degree, 3.5 Degree	1144	1
Offset Bush Kit	2 Degree	1144SK	1

REAR SUSPENSION

Product		Part Number	Qty Req'd
SHOCK ABSORBER			
Nitro Gas		12094GR	2
Foam Cell		24094FE	2
Foam Cell	Extra Long Travel	24094LFE	2
LEAF SPRING		Additional Weight	
Comfort	0-150kg	TOY047A	2
Performance	0-250kg	TOY047B	2
Constant Load	250-400kg	TOY047C	2
Mining	400kg-GVM	TOY047D	2
U-BOLTS			
U-Bolt Kit		416UBK	2
POLYURETHANE SPRING BUSHES			
Complete Set		1085UK	1
GREASABLE SHACKLES & PINS			
Greasable Shackle	Must Use Ironman Bushes	1141	2
Greasable Pin	Must Use Ironman Bushes	1142	2

SUSPENSION KIT

Product	Part Number
Comfort with Gas Shocks	TOY046AKG1
Comfort with Foam Cell Shocks	TOY046AKF1
Performance with Gas Shocks	TOY046BKG1
Performance with Foam Cell Shocks	TOY046BKF1
Constant Load with Gas Shocks	TOY046CKG1
Constant Load with Foam Cell Shocks	TOY046CKF1
Mining with Gas Shocks	TOY046DKG1
Mining with Foam Cell Shocks	TOY046DKF1

NOTE: Image above indicates kit contents.

LANDCRUISER

80 SERIES / 105 SERIES WAGON

Solid Axle Front Suspension, 1990 On
50mm Lift**FRONT SUSPENSION**

Product		Part Number	Qty Req'd
SHOCK ABSORBER			
Nitro Gas		12683GR	2
Foam Cell		24683FE	2
COIL SPRING			
	Additional Weight		
Performance	0-50kg	TOY024B	1
Constant Load	50-110kg	TOY024C	1
STEERING DAMPER			
Foam Cell		3524	1
OFFSET CASTER BUSH KIT			
Adjustable Offset Bush Kit	STD, 2.5 Degree, 3.5 Degree	1144	1
Offset Bush Kit	2 Degree	1144SK	1
TRIM PACKER			
20mm Coil Spring Trim Packer		LCF20	2
30mm Coil Spring Trim Packer		LCF30	2

REAR SUSPENSION

Product		Part Number	Qty Req'd
SHOCK ABSORBER			
Nitro Gas		12682GR	2
Foam Cell		24682FE	2
COIL SPRING			
	Additional Weight		
Performance	0-200kg	TOY025B	1
Performance with Accessories	100-300kg	TOY013B	1
Constant Load	300-400kg	TOY025C	1
Extra Constant Load	400kg-GVM	TOY025D	1
TRIM PACKER			
15mm Coil Spring Trim Packer		LCR15	2
30mm Coil Spring Trim Packer		LCR30	2

BUSH KIT

Product	Part Number	Qty Req'd
Suspension Arm Bush Kit	847K	1

SUSPENSION KIT

Product	Part Number
Performance with Gas Shocks	TOY024BKG
Performance with Foam Cell Shocks	TOY024BKF
Constant Load with Gas Shocks	TOY024CKG
Constant Load with Foam Cell Shocks	TOY024CKF
Extra Constant Load with Gas Shocks	TOY024DKG
Extra Constant Load with Foam Cell Shocks	TOY024DKF

NOTE: Image above indicates kit contents.

NOTE: Vehicle manufactured pre 8/1991 result in 20mm lower lift than post 8/1991.

NOTE: For competition vehicle / big lift applications - see Page 95.



FRONT SUSPENSION

Product	Part Number	Qty Req'd
---------	-------------	-----------

SHOCK ABSORBER

Nitro Gas	12795GR	2
Foam Cell	24795FE	2

SPRING

Up-rated Torsion Bar	<i>Must Install BRACKET100</i>	TOY050	1
----------------------	--------------------------------	--------	---

BRACKET

Control Arm Reinforcement	BRACKET100	1
---------------------------	------------	---

REAR SUSPENSION

Product	Part Number	Qty Req'd
---------	-------------	-----------

SHOCK ABSORBER

Nitro Gas	12796GR	2
Foam Cell	24796FE	2

COIL SPRING

Additional Weight

Performance	0-200kg	TOY013B	1
Constant Load	200-400kg	TOY025C	1

TRIM PACKER

15mm Coil Spring Trim Packer	LCR15	2
30mm Coil Spring Trim Packer	LCR30	2

SUSPENSION KIT

Product	Part Number
---------	-------------

Performance with Gas Shocks	TOY050BKG
Performance with Foam Cell Shocks	TOY050BKF
Constant Load with Gas Shocks	TOY050CKG
Constant Load with Foam Cell Shocks	TOY050CKF

NOTE: Image above indicates kit contents.

When setting Torsion Bar ride height, it is essential to maintain a minimum of 60mm downward suspension travel.

LANDCRUISER

100 SERIES WAGON, DIESEL

Independent Front Suspension, 10/2000 On
25mm Lift**FRONT SUSPENSION**

Product	Part Number	Qty Req'd
---------	-------------	-----------

SHOCK ABSORBER

Nitro Gas	12795GR	2
Foam Cell	24795FE	2

SPRING

Up-rated Torsion Bar	<i>Must Install BRACKET100</i>	TOY051	1
----------------------	--------------------------------	--------	---

BRACKET

Control Arm Reinforcement	BRACKET100	1
---------------------------	------------	---

REAR SUSPENSION

Product	Part Number	Qty Req'd
---------	-------------	-----------

SHOCK ABSORBER

Nitro Gas	12796GR	2
Foam Cell	24796FE	2

COIL SPRING**Additional Weight**

Performance	0-200kg	TOY013B	1
Constant Load	200-400kg	TOY025C	1

TRIM PACKER

15mm Coil Spring Trim Packer	LCR15	2
30mm Coil Spring Trim Packer	LCR30	2

SUSPENSION KIT

Product	Part Number
---------	-------------

Performance with Gas Shocks	TOY051BKG
Performance with Foam Cell Shocks	TOY051BKF
Extra Constant Load with Gas Shocks	TOY051CKG
Extra Constant Load with Foam Cell Shocks	TOY051CKF

NOTE: Image above indicates kit contents.

When setting Torsion Bar ride height, it is essential to maintain a minimum of 60mm downward suspension travel.



LANDCRUISER
200 SERIES WAGON
 Independent Front Suspension
 45mm Lift

FRONT SUSPENSION

Product		Part Number	Qty Req'd
SHOCK ABSORBER			
Nitro Gas	<i>Height Adjustable Strut</i>	12720GR	2
COIL SPRING			
Performance	<i>0-50kg</i>	TOY063B	1
Constant Load	<i>50-110kg</i>	TOY063C	1
TRIM PACKER			
10mm Spacer	<i>Ironman Struts Only</i>	HILFR10	2
15mm Spacer	<i>Ironman Struts Only</i>	HILFR15	2

REAR SUSPENSION

Product		Part Number	Qty Req'd
SHOCK ABSORBER			
Nitro Gas		12796GR	2
Foam Cell		24796FE	2
COIL SPRING			
Performance	<i>0-300kg</i>	TOY064B	1
Constant Load	<i>300kg-GVM</i>	TOY064C	1

SUSPENSION KIT

Product	Part Number
Performance with Gas Shocks	TOY063BKG
Performance with Foam Cell Shocks (Rear)	TOY063BKF
Constant Load with Gas Shocks	TOY063CKG
Constant Load with Foam Cell Shocks (Rear)	TOY063CKF

NOTE: Image above indicates kit contents.

**Unnecessary fitment of Trim Packers may lift vehicle too high.
 It is also essential to select the correct front coil springs to
 maintain a minimum of 60mm downward suspension travel.**

PRADO

90 / 95 SERIES
1996 - 10/2002
45mm Lift

**4RUNNER**

VZN/RZN 180/185
1996 - 2002
45mm Lift

**FRONT SUSPENSION**

Product		Part Number	Qty Req'd
SHOCK ABSORBER			
Nitro Gas	<i>Height Adjustable Strut</i>	12691GR	2
COIL SPRING			
	Additional Weight		
Petrol no Accesories	<i>0-50kg</i>	TOY038B	1
Turbo Diesel or Accesories	<i>50-100kg</i>	TOY038C	1
TRIM PACKER			
10mm Spacer	<i>Ironman Struts Only</i>	HILFR10	2
15mm Spacer	<i>Ironman Struts Only</i>	HILFR15	2

REAR SUSPENSION

Product		Part Number	Qty Req'd
SHOCK ABSORBER			
Nitro Gas		12661GR	2
Foam Cell		24661FE	2
COIL SPRING			
	Additional Weight		
Performance SWB	<i>0-300kg</i>	TOY039A	1
Performance LWB	<i>0-300kg</i>	TOY039B	1
TRIM PACKER			
20mm Coil Spring Trim Packer		LCF20	2
30mm Coil Spring Trim Packer		LCF30	2

SUSPENSION KIT

Product	Part Number
SWB Petrol with Gas Shocks	TOY038AKG
SWB Petrol with Foam Cell Shocks (Rear)	TOY038AKF
SWB Diesel with Gas Shocks	TOY038AKG1
SWB Diesel with Foam Cell Shocks (Rear)	TOY038AKF1
LWB Petrol with Gas Shocks	TOY038BKG
LWB Petrol with Foam Cell Shocks (Rear)	TOY038BKF
LWB Diesel with Gas Shocks	TOY038CKG
LWB Diesel with Foam Cell Shocks (Rear)	TOY038CKF

NOTE: Image above indicates kit contents.

**Unnecessary fitment of Trim Packers may lift vehicle too high.
It is also essential to select the correct front coil springs to
maintain a minimum of 60mm downward suspension travel.**



PRADO
120 SERIES
 4/2003 On
 45mm Lift

FRONT SUSPENSION

Product		Part Number	Qty Req'd
SHOCK ABSORBER			
Nitro Gas	<i>Height Adjustable Strut</i>	12710GR	2
COIL SPRING			
	Additional Weight		
Petrol no Accesories	<i>0-50kg</i>	TOY055B	1
Diesel or Accesories	<i>50-100kg</i>	TOY055C	1
TRIM PACKER			
10mm Spacer	<i>Ironman Struts Only</i>	HILFR10	2
15mm Spacer	<i>Ironman Struts Only</i>	HILFR15	2

REAR SUSPENSION

Product		Part Number	Qty Req'd
SHOCK ABSORBER			
Nitro Gas	<i>Comfort Soft Ride</i>	12682GRC	2
Nitro Gas		12682GR	2
Foam Cell		24682FE	2
COIL SPRING			
	Additional Weight		
Performance	<i>0-300kg</i>	TOY056B	1
Constant Load	<i>300kg-GVM</i>	TOY056C	1

SUSPENSION KIT

Product	Part Number
Performance Petrol with Gas Shocks	TOY055BKG
Performance Petrol with (Foam Cell Shocks Rear)	TOY055BKF
Constant Load Petrol with Gas Shocks	TOY055CKG
Constant Load Petrol with (Foam Cell Shocks (Rear)	TOY055CKF
Performance Diesel with Gas Shocks	TOY055BKG1
Performance Diesel with (Foam Cell Shocks Rear)	TOY055BKF1
Constant Load Diesel with Gas Shocks	TOY055CKG1
Constant Load Diesel with (Foam Cell Shocks (Rear)	TOY055CKF1

NOTE: Image above indicates kit contents.

**Unnecessary fitment of Trim Packers may lift vehicle too high.
 It is also essential to select the correct front coil springs to
 maintain a minimum of 60mm downward suspension travel.**

FJ CRUISER2006 On
45mm Lift**FRONT SUSPENSION**

Product		Part Number	Qty Req'd
SHOCK ABSORBER			
Nitro Gas	<i>Height Adjustable Strut</i>	12710GR	2
COIL SPRING			
	Additional Weight		
Petrol no Accesories	<i>0-50kg</i>	TOY055B	1
Diesel or Accesories	<i>50-100kg</i>	TOY055C	1
TRIM PACKER			
10mm Spacer	<i>Ironman Struts Only</i>	HILFR10	2
15mm Spacer	<i>Ironman Struts Only</i>	HILFR15	2

REAR SUSPENSION

Product		Part Number	Qty Req'd
SHOCK ABSORBER			
Nitro Gas	<i>Comfort Soft Ride</i>	12682GRC	2
Nitro Gas		12682GR	2
Foam Cell		24682FE	2
COIL SPRING			
	Additional Weight		
Performance	<i>0-300kg</i>	TOY056B	1
Constant Load	<i>300kg-GVM</i>	TOY056C	1

SUSPENSION KIT

Product	Part Number
Performance Petrol with Gas Shocks	TOY055BKG
Performance Petrol with (Foam Cell Shocks Rear)	TOY055BKF
Constant Load Petrol with Gas Shocks	TOY055CKG
Constant Load Petrol with (Foam Cell Shocks (Rear)	TOY055CKF
Performance Diesel with Gas Shocks	TOY055BKG1
Performance Diesel with (Foam Cell Shocks Rear)	TOY055BKF1
Constant Load Diesel with Gas Shocks	TOY055CKG1
Constant Load Diesel with (Foam Cell Shocks (Rear)	TOY055CKF1

NOTE: Image above indicates kit contents.

**Unnecessary fitment of Trim Packers may lift vehicle too high.
It is also essential to select the correct front coil springs to
maintain a minimum of 60mm downward suspension travel.**



FORTUNER
11/2004 On
45mm Lift

FRONT SUSPENSION

Product		Part Number	Qty Req'd
SHOCK ABSORBER			
Nitro Gas	<i>Height Adjustable Strut</i>	12710GR	2
COIL SPRING			
Performance	<i>0-50kg</i>	TOY055B	1
Constant Load	<i>50-100kg</i>	TOY055C	1
TRIM PACKER			
10mm Spacer	<i>Ironman Struts Only</i>	HILFR10	2
15mm Spacer	<i>Ironman Struts Only</i>	HILFR15	2

REAR SUSPENSION

Product		Part Number	Qty Req'd
SHOCK ABSORBER			
Nitro Gas	<i>Comfort Soft Ride</i>	12637GRC	2
Nitro Gas		12637GR	2
Foam Cell		24637FE	2
COIL SPRING			
Comfort	<i>0-100kg</i>	TOY017A	1
Performance	<i>0-300kg</i>	TOY017B	1

SUSPENSION KIT

Product	Part Number
Petrol with Gas Shocks	TOY017BKG
Petrol with (Foam Cell Shocks Rear)	TOY017BKF
Diesel with Gas Shocks	TOY017BKG1
Diesel with (Foam Cell Shocks Rear)	TOY017BKF1

NOTE: Image above indicates kit contents.

**Unnecessary fitment of Trim Packers may lift vehicle too high.
It is also essential to select the correct front coil springs to
maintain a minimum of 60mm downward suspension travel.**

PATROL
GQ Y60 / GU Y61 LWB
1988 On



FRONT SUSPENSION

Product		Part Number	Qty Req'd
SHOCK ABSORBER			
Foam Cell	Suit 4" Lift	24091LFE	2
Foam Cell	Suit 6" Lift	24091LFE1	2
COIL SPRING			
	Additional Weight		
4" Lift	0-100kg	NISS026B	1
6" Lift	0-100kg	NISS043B	1
STEERING DAMPER			
Foam Cell	GQ Pre 8/1989	3534	1
Foam Cell	GQ Post 8/1989	3536	1
Foam Cell	GU Pre 2/2000	3511	1
Foam Cell	GU Post 2/2000	3501	1
OFFSET CASTER			
5° Offset Caster Plates	Suit 4"-6" Lift	CPLATE003	1
SPACERS & RODS			
Extended Brake Hose	Non ABS Models	BHOSE003	1
15mm Coil Spring Trim Packer		PATF15	2
30mm Coil Spring Trim Packer		PATF30	2
Crossmember Spacer Kit	GQ Only	1002K	1
Extended Sway Bar Link		SBEXT003	2
Adjustable Panhard Rod	RHD / GQ / GU S1	PANHARD003	1
Adjustable Panhard Rod	RHD / GU S2+	PANHARD005	1
Adjustable Panhard Rod	LHD / GQ / GU S1	PANHARD008	1
Adjustable Panhard Rod	LHD / GU S2+	PANHARD009	1

REAR SUSPENSION

Product		Part Number	Qty Req'd
SHOCK ABSORBER			
Foam Cell	Suit 4" Lift	24094LFE	2
Foam Cell	Suit 6" Lift	24094LFE1	2
COIL SPRING			
	Additional Weight		
4" Lift	0-200kg	NISS027B	1
6" Lift	0-200kg	NISS044B	1
SPACERS & RODS			
Extended Brake Hose	Non ABS Models	BHOSE004	1
15mm Coil Spring Trim Packer		PATR15	2
30mm Coil Spring Trim Packer		PATR30	2
Extended Sway Bar Link	Stem / Right Angle Joint	SBEXT003*	1
Extended Sway Bar Link	Right Angle / Right Angle Joint	SBEXT004*	1
Adjustable Panhard Rod	GQ / GU S1	PANHARD004	1
Adjustable Panhard Rod	GU S2+	PANHARD006	1

SUSPENSION KIT

Product		Part Number
4" Lift Suspension Kit	GQ / GU S1	NISS026BKF*
6" Lift Suspension Kit	GQ / GU S1	NISS043BKF*
4" Lift Suspension Kit	GU S2+	NISS026BKF1*
6" Lift Suspension Kit	GU S2+	NISS043BKF1*

***IMPORTANT:** Please check your rear sway bar link configuration.

NOTE: Image above indicates kit contents.

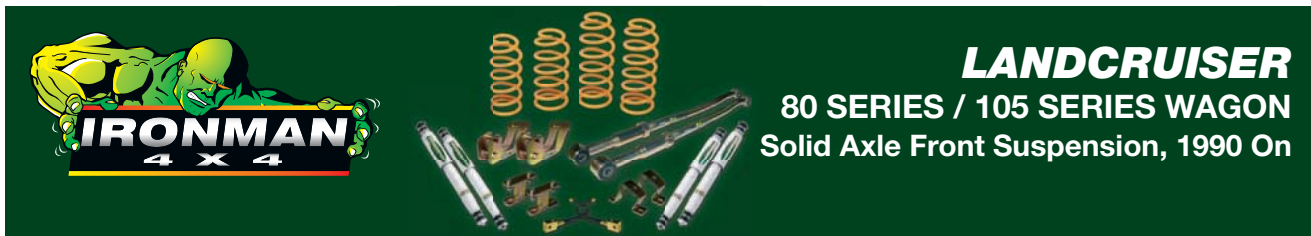

FRONT SUSPENSION

Product		Part Number	Qty Req'd
SHOCK ABSORBER			
Foam Cell	<i>Suit 4" Lift</i>	24683LFE	2
Foam Cell	<i>Suit 6" Lift</i>	24683LFE1	2
COIL SPRING			
	Additional Weight		
4" Lift	<i>0-100kg</i>	TOY012C	1
6" Lift	<i>0-100kg</i>	TOY060B	1
STEERING DAMPER			
Foam Cell		3524	1
OFFSET CASTER			
Adjustable Offset Bush Kit	<i>Suit 3" - 4" Lift</i>	1144	1
5° Offset Caster Plates	<i>Suit 4" - 6" Lift</i>	CPLATE001	1
SPACERS & RODS			
Extended Brake Hose	<i>Non ABS Models</i>	BHOSE001 ¹	1
20mm Coil Spring Trim Packer		LCF20	2
30mm Coil Spring Trim Packer		LCF30	2
Extended Sway Bar Bracket		SBEXT001	2
Adjustable Panhard Rod	<i>RHD</i>	PANHARD001	1
Adjustable Panhard Rod	<i>LHD</i>	PANHARD007	1

REAR SUSPENSION

Product		Part Number	Qty Req'd
SHOCK ABSORBER			
Foam Cell	<i>Suit 4" Lift</i>	24682LFE	2
Foam Cell	<i>Suit 6" Lift</i>	24682LFE1	2
COIL SPRING			
	Additional Weight		
4" Lift	<i>0-200kg</i>	TOY013C	1
6" Lift	<i>0-200kg</i>	TOY061B	1
SPACERS & RODS			
Extended Brake Hose	<i>Non ABS Models</i>	BHOSE002	1
15mm Coil Spring Trim Packer		LCR15	2
30mm Coil Spring Trim Packer		LCR30	2
Extended Sway Bar Bracket	<i>Side Chassis Mounting</i>	SBEXT002 ²	2
Extended Sway Bar Bracket	<i>Under Chassis Mounting</i>	SBEXT005 ²	2
Adjustable Panhard Rod		PANHARD002	1

SUSPENSION KIT

Product		Part Number
4" Lift Suspension Kit	<i>80 Series</i>	TOY012CKF1
6" Lift Suspension Kit	<i>80 Series</i>	TOY063BKF1
4" Lift Suspension Kit	<i>105 Series</i>	TOY012CKF2
6" Lift Suspension Kit	<i>105 Series</i>	TOY063BKF2

Products listed on page 94 -95 may not be legal for road use and are strictly intended for off-road competition use only. Certification may be required for on-road use.

The above products are not covered by the Ironman warranty policy.

Further vehicle modifications may be necessary. Such modifications are entirely the owners responsibility. Ironman accept no responsibility for any damage or injury caused by use of the above products.

* Vehicles manufactured pre 8/1991 result in 20mm lower lift than post 8/1991.

¹ Landcruiser with two Front Brake Hoses, order extra BHOSE002 for Front.

² 80 Series may have SBEXT002 or SBEXT005, 105 Series will use SBEXT005. 80 Series must check your Rear Sway Bar Bracket before ordering.

NOTE: Image above indicates kit contents.



SPRING NUMBER	WIRE DIAMETER (mm)	FREE HEIGHT (mm)	END I/D (mm)
HOLD008B	16.4	425	104
HOLD008C	17	420	106
HYUND003B	17	407	148
JEEP003B D/S N/S	15	432/436	65/100
JEEP006B D/S N/S	14	380/375	62/102.5
JEEP007B D/S N/S	15	440/435	66/100
JEEP008B D/S N/S	16	345/335	72
JEEP012B D/S N/S	15	420/410	98
JEEP013B D/S N/S	16	350/340	75
JEEP014B	16.5	375	82
JEEP014C	16.5	382	82
JEEP015B	17	323	85/117
JEEP016B	15.5	465	70/102
KIA006B	18	342	61/91
KIA007B	16	387	79/129
LADA001B	16	285	92
LADA002B	14	435	100
LAND005B	17	400	118
LAND006B	20	405	134
LAND006C	21	440	134
LAND007B D/S N/S	16	390/382	118
LAND008B	17	440	134
LAND009B D/S N/S	16	405/395	117
LAND011B D/S N/S	17	425/420	117
LAND011C D/S N/S	18	425/420	118
LAND014B D/S N/S	15	410/390	117
MITS020B D/S N/S	17	405/400	145
MITS022B D/S N/S	16	410/400	145
MITS025B	17	390	124
MITS038B	19	323	72/93
MITS038C	19	336	72/93
MITS039A D/S N/S	21	330/320	113.5
MITS039B D/S N/S	21	350/340	113.5
MITS040B	19	325	64/93
MITS040C	19	318	64/93
NISS007B D/S N/S	16	415/400	89/122
NISS008B D/S N/S	17	490/480	139
NISS009B D/S N/S	17	410/387	87/122
NISS009C D/S N/S	18	415/398	89/122
NISS010B D/S N/S	19	468/448	139
NISS010C D/S N/S	19	488/470	139
NISS018B	14	427	106
NISS020B D/S N/S	19	490/480	139
NISS020C D/S N/S	20	475/458	139
NISS020D D/S N/S	22	475/453	139
NISS024B D/S N/S	17	425/410	87/122
NISS026B D/S N/S	18	484/469	87/122
NISS027B D/S N/S	20	535/521	139
NISS034B	16	400	119/146.5
NISS035B	15	370	126
NISS038B	15	325	134/176
NISS039B	15	325	114/176
NISS040B	17	370	81
NISS040C	17	380	81
NISS042B	19	443	119
NISS042C	20	443	119
NISS043B D/S N/S	19	525/510	87/122
NISS044B D/S N/S	21	590/575	139

SPRING NUMBER	WIRE DIAMETER (mm)	FREE HEIGHT (mm)	END I/D (mm)
SSANG002B	16	410	116
SUB001B	15	350	123/144
SUB002B D/S N/S	15	345/340	128
SUB003B	15.5	355	123/144
SUB004B	15	365	99/135
SUZ004B	12	345	70/82.5
SUZ003B	16	280	70.5/82.5
SUZ005B	16	290	70.5/82.5
SUZ006B	13	340	72/82
SUZ007B D/S N/S	10	308/293	70
SUZ008B	11	322	82.5
SUZ013B	12.5	345	62/80
SUZ015B	16	320	72/82
SUZ016B	12.5	360	62/80
SUZ017B	16	340	72/82
SUZ018B	14	360	63/96
TOY012C D/S N/S	19	515/520	84/119
TOY013B D/S N/S	18	485/495	108/140
TOY013C D/S N/S	20	490/497	108/140
TOY017A	16	445	90
TOY017B	16	445	90
TOY018B D/S N/S	14	395/380	86/100
TOY019B D/S N/S	16	420/405	86/125
TOY023B D/S N/S	16	390/385	103/133
TOY023C D/S N/S	17	375/370	103/134
TOY024B D/S N/S	17	480/485	81/116
TOY024C D/S N/S	17	500/505	82/117
TOY025B D/S N/S	18	473/483	108/139
TOY025C D/S N/S	19	460/475	107/139
TOY025D D/S N/S	22	470/478	108/140
TOY038B D/S N/S	16	348/357	67/76
TOY038C	17	365	67/76
TOY039A	15	398	74/114
TOY039B	15	410	74/114
TOY046B	17	458	86/100
TOY046C	18	450	86/100
TOY048B	14	438	100
TOY049B	17	450	87/125
TOY055B	17	380	66/76
TOY055C	18	373	66/76
TOY056B	17	392	83/130
TOY056C	18	392	85/130
TOY060B D/S N/S	20	614/622	84/119
TOY061B D/S N/S	21	627/637	108/140
TOY063B D/S N/S	19	470/460	73/89
TOY063C D/S N/S	19	475/465	73/89
TOY064B D/S N/S	19	485/470	108/144
TOY064C D/S N/S	21	475/465	108/144

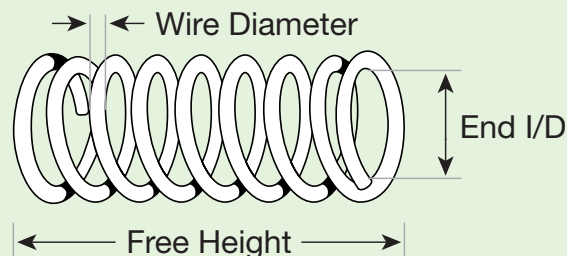



SPRING NUMBER	LENGTH A (mm)	LENGTH B (mm)	CAMBER (mm)	LEAVES
HOLD004A D/S N/S	550	650	250/240	5+1
HOLD004B D/S N/S	550	650	250/240	5+1
HOLD004C D/S N/S	550	650	250/240	6+1
HOLD006A	600	600	225	4+1
HOLD006B	600	600	220	5+1
HOLD006C	600	600	220	6+1
JEEP004B	585	725	200/180	5+2
MAZDA006A	530	670	165	5+1
MAZDA006B	530	675	150	6+2
MAZDA006C	530	675	165	6+2
MAZDA006D	530	675	150	7+2
MAZDA041A	590	730	140	4+2
MAZDA041B	590	730	140	4+2
MAZDA041C	590	720	140	5+2
MAZDA041D	590	720	130	6+2
MITSO18A	520	685	200	4+1
MITSO18B	515	685	195	4+1
MITSO18C	517.5	687.5	190	5+1
MITSO41A	515	685	150	4+1
MITSO41B	515	685	155	4+1
MITSO41C	515	685	155	5+1
NISS003B D/S N/S	560	550	185/170	6
NISS004B D/S N/S	604	838	250/235	8
NISS005B D/S N/S	560	550	185/170	6
NISS011C D/S N/S	550	550	180/170	7
NISS012C D/S N/S	595	825	217/200	7+2
NISS012D D/S N/S	600	830	240/225	7+3
NISS014A D/S N/S	565	635	145/135	4+2
NISS014B D/S N/S	565	635	130/120	4+1
NISS014C D/S N/S	565	635	130/120	5+1
NISS014C D/S N/S	565	635	130/120	5+1
NISS021B	650	580	200	8
NISS041B	670	735	195	5+1
NISS041C	670	730	190	6+1

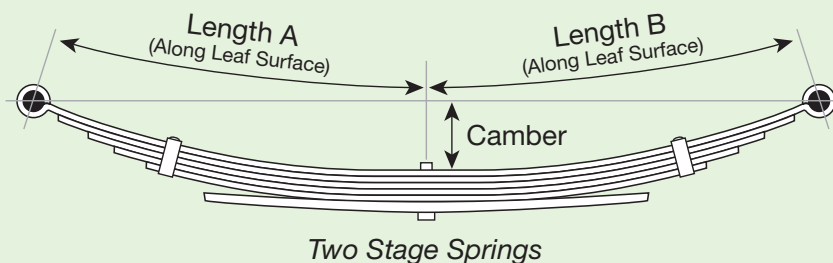
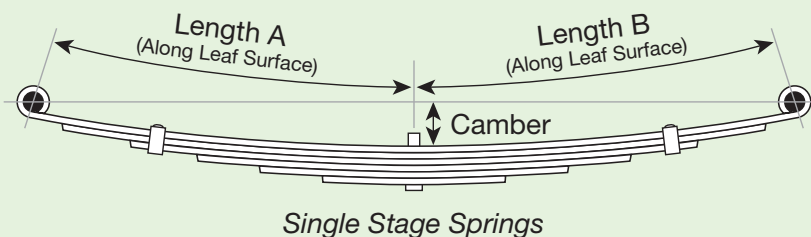



LEAF SPRINGS

SPRING NUMBER	LENGTH A (mm)	LENGTH B (mm)	CAMBER (mm)	LEAVES
SUZ001B D/S N/S	480	470	120/110	5
SUZ002B	510	520	155	4+1
TOY001B	505	605	165	7
TOY002B	505	620	180	7
TOY003C	660	660	230	7+3
TOY004B	502	603	165	7
TOY004C	502	603	155	8
TOY005C	655	675	230	7+3
TOY006B	550	550	150	7
TOY006C	550	550	175	8
TOY006D	550	550	175	9
TOY007A D/S N/S	565	655	230/220	7
TOY007B D/S N/S	565	645	220/205	6+1
TOY007C D/S N/S	565	655	230/220	7+1
TOY008B	550	590	180	7
TOY008C	550	590	180	8
TOY009B	600	730	210	6+2
TOY009C	603	720	210	7+2
TOY009D	600	720	215	8+2
TOY009E	605	720	220	9+2
TOY010B D/S N/S	575	575	135/115	5
TOY010C D/S N/S	575	575	130/110	6
TOY011B	530	670	200	4+2
TOY011C	530	670	210	5+2
TOY027A	560	740	200	6+2
TOY027B	560	740	200	4+2
TOY027C	560	740	200	5+2
TOY034B	505	630	205	7
TOY047A	690	815	245	7+2
TOY047B	690	815	245	8+2
TOY047C	690	815	245	9+2
TOY047D	693	820	265	9+3
TOY057A	610	690	180	6+2
TOY057B	610	690	200	4+2
TOY057C	610	690	200	5+2
TOY062B	615	785	235	6+2
TOY062C	615	785	235	7+2

TORSION BARS



TORSION BAR NUMBER	BAR LENGTH (mm)	BAR DIAMETER (mm)
HOLD003A	927	26
HOLD005A	1000	26
HOLD007	1000	26
HOLD009	1220	30
HOLD010	1144	30
HYUND004B	1275	29.3
MAZDA005	924	26
MAZDA014	1025	27
MITS013	1278	26
MITS015C	1370	27.5
MITS019	1308	27.5
MITS031	1165	24
NISS013	1203	26
NISS017	1232	26
NISS025	891	26
SSANG001	1040	26
TOY026	1063	26
TOY050	1160	32
TOY051	1210	32

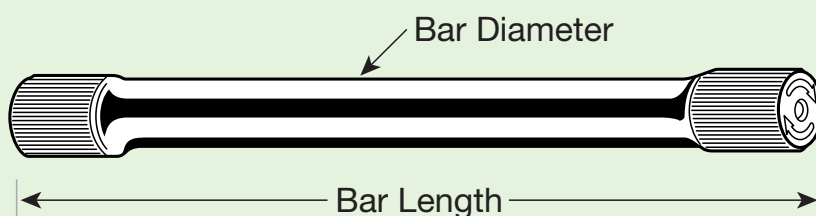



U-BOLTS

UBOLT NUMBER	TYPE	LENGTH (mm)	I/D (mm)	THREAD
415	ROUND	215	83	M14 X 1.5 X 100
416	ROUND	230	83	M14 X 1.5 X 100
417	ROUND	220	88	M14 X 1.5 X 80
436	SQUARE	230	73	M14 X 1.5 X 100
437	SQUARE	175	62	M14 X 1.5 X 100
449	SQUARE	230	83	M14 X 1.5 X 100
451	ROUND	190	75	M12 X 1.5 X 75
452	SQUARE	120	63	M12 X 1.5 X 75
453	ROUND	230	97	M14 X 1.5 X 100
512	ROUND	160	70	M12 X 1.5 X 65
654	ROUND	165	82	M12 X 1.5 X 75
655	ROUND	140	70	M12 X 1.5 X 65
658	ROUND	170	65	M12 X 1.25 X 65
659	ROUND	170	80	M12 X 1.25 X 65
663	ROUND	220	90	M12 X 1.25 X 120
668	SQUARE	230	73	M14 X 1.5 X 100
669	SQUARE	230	73	M14 X 1.5 X 100
670	ROUND	230	95	M14 X 1.5 X 100
678	SQUARE	200	62	M14 X 1.5 X 70
788	SQUARE	190	63	M12 X 1.25 X 65
1100	ROUND	230	110	M14 X 1.5 X 100
1102	SQUARE	155	72	M12 X 1.5 X 65

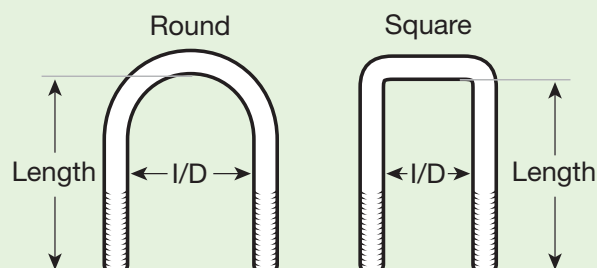

COIL SPRING SPACERS

SPACER NUMBER	O/D (mm)	I/D (mm)	THICKNESS (mm)	MATERIAL
HILFR10 / 15	63	54.55	10 / 15	STEEL
LCF20 / 30	160	114.5	20 / 30	POLYURETHANE
LCR15 / 30	187	133.5	15 / 30	POLYURETHANE
PATF15 / 30	172	116	15 / 30	POLYURETHANE
PATR15 / 30	180	120	15 / 30	POLYURETHANE



SHOCK ABSORBER BOOTS

BOOT NUMBER	END I/D (mm)	MIN LENGTH (mm)	MAX LENGTH (mm)
I42006	40/56	60	190
I42006A	40/56	65	225
I42007	40/56	100	290

GAS SHOCK ABSORBERS



SHOCK ABSORBER	EXTENDED (mm)	COMPRESSED (mm)	UPPER MOUNT TYPE	LOWER MOUNT TYPE
12075GR	487	296	ST1	ST1
12076GR	583	347	B1	ST1
12080GR	552	332	ST38	ST38
12081GR	631	388	B2	B2
12082GR	342	227	ST1	CB7
12083GR	505	312	STEM 57 X M14	-
12085GR	485	297	ST1	B1
12086GR	500	310	B1	B1
12087GR	351	229	ST1	ET17
12088GR	368	245	ST1	ET113
12089GR	510	320	ST1	ET83
12091GR	510	310	ST38	ST38
12094GR	655	402	B2	B2
12095GR	631	382	ET104	ET69
12635GR	485	307	B1	B1
12636GR	588	357	B1	B1
12637GR	577	348	ST1	B2
12639GR	484	298	ST1	ET17
12640GR	563	343	B2	ST38
12643GR	412	261	ST6	ET17
12644GR	510	320	ET153	ET36
12645GR	531	333	B1	ET142
12646GR	496	311	ST1	ET113
12648GR	640	385	B2	ST1
12650GR	592	362	B2	B2
12652GR	540	335	B1	B1
12658GR	510	320	ST1	ET83
12661GR	535	329	ST1	B2
12665GR	565	345	ST1	CB7
12666GR	560	340	CB20	B5
12667GR	381	245	ST1	ET17
12669GR	560	340	CB20	ET24
12670GR	562	342	B5	ET24
12671GR	627	372	ST1	B1
12682GR	618	373	ST38	B2
12683GR	615	365	ST38	ST38
12691GR STRUT	462	343	ST38	ET153
12696GR	560	336	ET161	ST1
12697GR	520	320	B2	ST1
12698GR	624	381	B1	B1
12710GR STRUT	540	408	STEM 95.5 X M12	ET153-1
12711GR STRUT	317	205	STEM 68.5 X M10	-
12712GR	570	355	ET19	ET141
12713GR STRUT	470	325	STEM 86.5 X M10	ET158
12714GR	575	350	ST1	ET158
12715GR STRUT	418	300	STEM 71 X M10	ET158-1
12716GR STRUT	387	282	STEM 85 X M12	ET34
12717GR	575	350	B1	ET34

SHOCK ABSORBER	EXTENDED (mm)	COMPRESSED (mm)	UPPER MOUNT TYPE	LOWER MOUNT TYPE
12718GR	380	265	ET158	ET158
12720GR	600	435	STEM 69 X M14	ET113
12774GR	550	330	ST6	CB7
12775GR	575	350	ET61	ET65
12776GR	585	362	ET172	CB34
12777GR	587	362	ET172	ET172
12791GR	310	215	ST1	ET17
12795GR	442	290	ST21	ET153
12796GR	615	365	ST21	B2

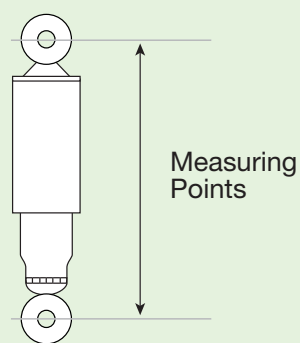
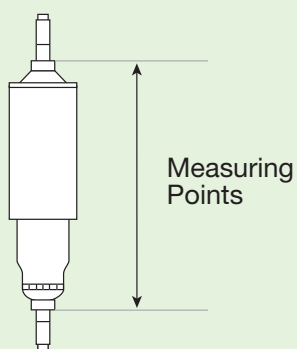
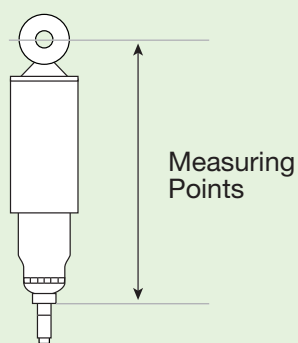

FOAM CELL SHOCK ABSORBERS



SHOCK ABSORBER	EXTENDED (mm)	COMPRESSED (mm)	UPPER MOUNT TYPE	LOWER MOUNT TYPE
24080FE	552	332	ST38	ST38
24081FE	631	388	B2	B2
24082FE	342	227	ST1	CB7
24087FE	351	229	ST1	ET17
24088FE	368	245	ST1	ET113
24091FE	510	310	ST38	ST38
24091LFE	557	327	ST38	ST38
24091LFE1	597	362	ST38	ST38
24094FE	655	402	B2	B2
24094LFE	718	425	B2	B2
24094LFE1	760	460	B2	B2
24095FE	631	382	ET104	ET69
24635FE	485	307	B1	B1
24636FE	588	357	B1	B1
24637FE	577	348	ST1	B2
24639FE	484	298	ST1	ET17
24640FE	563	343	B2	ST38
24643FE	412	261	ST6	ET17
24644FE	510	320	ET153	ET36
24645FE	531	333	B1	ET142
24646FE	496	311	ST1	ET113
24648FE	640	385	B2	ST1
24650FE	592	362	B2	B2
24652FE	540	335	B1	B1
24661FE	535	329	ST1	B2
24665FE	565	345	ST1	CB7
24666FE	560	340	CB20	B5
24667FE	381	245	ST1	ET17
24682FE	618	373	ST38	B2
24682LFE	670	393	ST38	B2
24682LFE1	730	423	ST38	B2
24683FE	615	365	ST38	ST38
24683LFE	670	385	ST38	ST38
24683LFE1	730	415	ST38	ST38
24696FE	560	336	ET161	ST1
24697FE	520	320	B2	ST1
24698FE	624	381	B1	B1
24776FE	587	362	ET172	CB34
24777FE	587	362	ET172	ET172
24795FE	442	290	ST21	ET153
24796FE	615	365	ST21	B2

DAMPER NUMBER	EXTENDED (mm)	COMPRESSED (mm)	UPPER MOUNT TYPE	LOWER MOUNT TYPE
3501	550	345	B9	B9
3502	655	394	ET65	ET65
3511	525	310	ST1	ST1
3517	609	368	B6	B6
3521	540	340	ST1	B9
3522	541	331	B1	B1
3523	458	322	B9	B9
3524	648	423	B9	B9
3525	748	443	B9	B9
3530	445	290	ET17	ET17
3532	677	439	ST1	ET57
3533	613	368	ET109	B9
3534	577	350	ET17	B1
3536	487	292	ST1	ST1
3540	501	312	B6	ET24

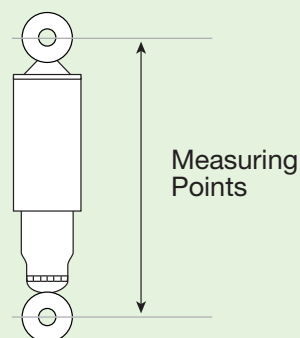
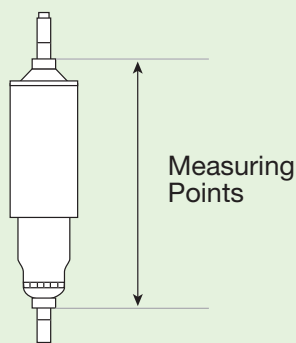
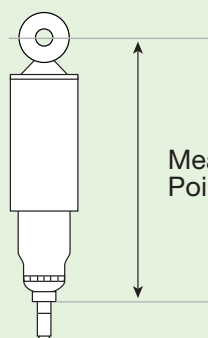

MOUNT CODES



MOUNT NUMBER	"A" DIAMETER (mm)	"B" LENGTH (mm)
B1	16	36
B2	19	43.5
B5	15.5	33

MOUNT NUMBER	"A" DIAMETER (mm)	"B" LENGTH (mm)
ET17	12.2	31.5
ET19	12.2	46
ET24	12.5	36
ET34	14.2	41.5
ET36	19.2	44
ET57	10	26.1
ET61	12.2	46
ET65	12.2	36
ET69	12.2	40
ET83	12.2	37.5
ET104	20.2	43
ET109	10	24.1
ET113	16.2	38.5
ET141	12.2	41
ET142	16.2	36.5
ET153	14	40
ET153-1	14	40
ET158	14.2	50
ET158-1	14.2	50
ET161	16.2	70
ET172	12.4	43.5

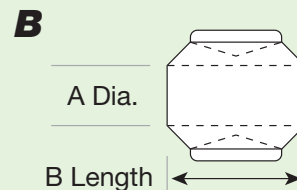

B6, B9

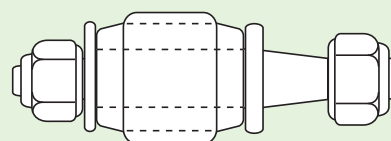

ET

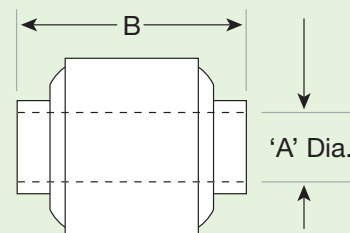

MOUNT NUMBER	"A" LENGTH (mm)	"B" LENGTH (mm)	"C" DIAMETER TYPE
ST1	60	26	10
ST6	65	34	11
ST21	84	59	17
ST38	70	43	14

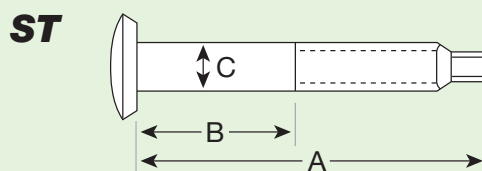

MOUNT NUMBER	"A" LENGTH (mm)	"B" LENGTH (mm)	"C" DIAMETER (mm)
CB7	78	62	11.5
CB20	95	77	13
CB34	97	75	11

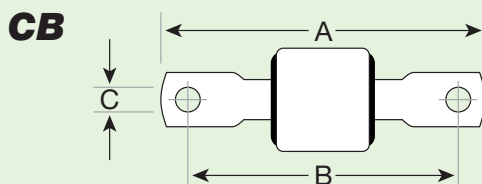

MAKE/MODEL	YEAR	PART #	MAKE/MODEL	YEAR	PART #
DAIHATSU			MAZDA		
Feroza F300, F310	88-99	LP1	Bravo/BT50	All	LP3
Feroza II	All	LP4	B1800/B2000 4x2	All	LP3
Rocky	All	LP1	B2200/B2600 4x2, 4x4	All	LP1
FORD			E1400	All	LP1
Courier / Ranger	All	LP3	E1800	All	LP1
Econovan & Spectron	All	LP1	E2000	All	LP1
Falcon Sedan XR-XD	All	LP4	E2200	All	LP1
Falcon Panel Van XR-XH	All	LP4	MERCEDES BENZ		
Falcon Utility 1 Ton XR-AU11	All	LP4	MB100	99-02	LP4
Bronco 4x4 (3" springs)	78-96	LP7	MB140	99-02	LP4
Bronco 4x4	66-77	LP4	Sprinter	98-01	LP4
Bronco II	82-91	LP4	MITSUBISHI		
F100, F150 4x2 (2.5" springs)	62-96	LP4	Pajero (leaf springs)	All	LP4
F100, F150 4x4 (3" springs)	70-96	LP7	Triton 4x2, 4x4	All	LP4
F150 4x2	97-01	LP4	L200/L300 Van	All	LP4
F150 4x4	97-01	LP7	Starwagon/Express Van	All	LP4
F250 Superduty	99-01	LP7	NISSAN/DATSUN		
F250 4x2	57-79	LP7	Navara D21, D22-4x2, 4x4	All	LP3
F250 4x4 (3" springs)	78-96	LP7	Navara D40	05 On	LP2
Transit Van (with leaf springs)	All	LP4	Urvan	All	LP3
* Not suitable Falcon wagon, except dedicated LPG			Patrol GQ/GU Cab/Chassis	88-01	LP4
HOLDEN			Patrol MQ/MK, G160, Y260	All	LP3
Commodore 1 Tonne	All	LP1	SUZUKI		
Jackaroo	All	LP3	Sierra	All	LP5
Rodeo 4x2, 4x4*	81-03	LP3	TOYOTA		
Shuttle	All	LP3	Hiace	All	LP3
Utility and Van HQ-WB	All	LP4	Hilux 4x2, 4x4	All	LP2
* Not suitable for Rodeo 2003-On models, with interleaf liners			Land Cruiser FJ40/BJ40-42	60-84	LP4
JEEP			Land Cruiser FJ/HJ60, 61, 62	80-90	LP4
Wrangler YJ	86-95	LP4	Land Cruiser HJ/HZJ 75*	84-99	LP4
KIA			Land Cruiser HZJ 78, 79*	99-02	LP9
Pregio	All	LP8	Land Cruiser 76	All	LP4
			4 Runner (leaf springs)	85-98	LP2
			Townace	All	LP1
			* Land Cruiser Drum brake rear models only		

LOAD PLUS	"WIDTH" (mm)	"THICKNESS" (mm)	"LENGTH" (mm)
LP1	60mm	x 12mm	x 425mm
LP2	60mm	x 12mm	x 420mm
LP3	60mm	x 12mm	x 442mm
LP4	70mm	x 12mm	x 442mm
LP5	50mm	x 8mm	x 310mm
LP6	60mm	x 12mm	x 425mm
LP7	75mm	x 12mm	x 438mm
LP8	70mm	x 11mm	x 380mm
LP9	70mm	x 16mm	x 435mm

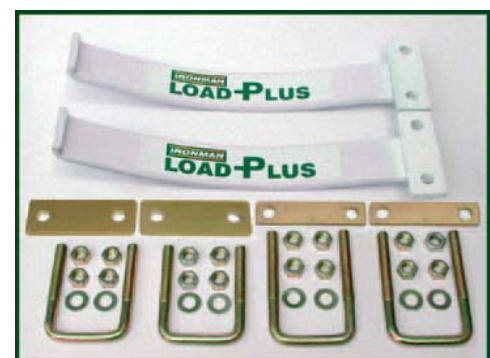





**Accessories
Catalogue**
Volume 2





WARRANTY	3
STEEL BULLBARS	4
BLACK COMMERCIAL.....	4
STAINLESS STEEL / HAMMERTONE	5
RECOVERY EQUIPMENT	6
ELECTRIC WINCH	6
HAND WINCH	6
KITS / STRAPS AND ACCESORIES	6
LIFTING JACKS	6
COMPRESSOR & TYRE REPAIR.....	6
FIRST AID	6
POWER MANAGEMENT	8
DUAL BATTERY KITS.....	8
LIGHTING	9
DRIVING LIGHTS	9
PORTABLE LED LIGHTING	9
CANOPIES	10
THERMO-PLAS CANOPIES.....	10
ACCESORIES	10
UTE LINERS	11
DUAL CAB UTE LINERS.....	11
ACCESORIES	11
STEPS AND BARS	12
STEEL SIDE STEPS	12
ALLOY SIDE STEPS	12
REAR STEP TOWBARS	12
STORAGE	13
UTE BOXES.....	13



Accessories (Excluding Winches) - 1 Year Warranty.

Winches - 3 Years Warranty.

Ironman 4x4 warrants the original buyer, only when purchased new via authorised Ironman 4x4 resellers and distributors, from date of retail sale.

Product is warranted against defects in material or workmanship that cause the product to perform below the specified limits set by Ironman 4x4, to the extent that Ironman 4x4 will repair or replace any parts which are found to be defective.

All warranty claims must be submitted via original purchasing store or chain, unless otherwise arranged.

Proof of original purchase must be presented upon request.

Products may require to be returned to Ironman 4x4 for assessment or repair. Postage and removal costs involved are not the responsibility of Ironman 4x4, and may only be considered upon discretion by Ironman 4x4 in the event of such claim being verified.

The warranty does NOT apply where, 1) acts of neglect or misuse are evident, 2) product has been modified, 3) vehicles which are modified or not the recommended vehicle of use, 4) used in racing or competition conditions without the prior consent of Ironman 4x4, 5) used beyond the expectations of the original vehicle manufacturer.

Before installation of any product, please ensure you have received the correct parts for your application.

Ordering of the correct parts is the responsibility of the buyer. Return of a product in an un-used condition will attract a 15% restock fee, where Ironman 4x4 is not at fault.

Return of used or soiled product, 1) outside warranty period, 2) without fault, will result in refusal of your claim and be returned at buyer's expense.

Damage to products through fitment error is not covered under warranty.

FREIGHT CONDITIONS:

Freight of all products is the buyer's responsibility.

Where Ironman 4x4 have arranged freight, costs involved will be invoiced to the buyer.

Ironman 4x4 is not responsible for damage or loss during freight.

FITTING:

Any prices quoted may be subject to fitting costs. The price of fitting is determined by the individual fitting agent.

STEEL BULLBARS

WINCH / AIRBAG COMPATIBLE



BLACK COMMERICAL

Product	Part Number
Toyota Hilux 1997-2004	BBC001
Toyota Hilux 2005-	BBC002
Holden Rodeo RA 2002-2005 RA	BBC003
Toyota LC80	BBC004
Toyota LC105	BBC005
Toyota LC100 IFS	BBC006
Toyota Prado 90	BBC007
Toyota Prado 120	BBC008
Nissan Patrol GU 1998-2004	BBC009
Nissan Patrol GQ	BBC010
Nissan Patrol GU S4 2005+	BBC011
Nissan Navara D40 Dual Cab	BBC012
Nissan Navara D40 Single Cab / Extra Cab	BBC012E
Nissan Navara D22	BBC013
Ford Ranger 2007-	BBC014
Ford Courier/Mazda Bravo 1996-2007 (with flares)	BBC015
Mitsubishi Triton ML 2006-	BBC016
Mitsubishi Triton MK 1996-2006	BBC017
Toyota LC75/78/79 1984-2007	BBC018
Toyota LC76/78/79 2007- (non flared model)	BBC019
Holden Rodeo RA7 / Isuzu D-Max 2007-	BBC020
Holden Rodeo TF/KB 1988-2003	BBC021
Hilux 105/106	BBC022
Mazda BT50 2007-	BBC024
Toyota LC200	BBC025
Holden Colorado 2008-	BBC027





STEEL BULLBARS WINCH / AIRBAG COMPATIBLE

PROTECTOR - STAINLESS STEEL / HAMMERTONE

Product	Part Number
Toyota Hilux 1997-2004	BBT001
Toyota Hilux 2005-	BBT002
Holden Rodeo RA 2002-2005 RA	BBT003
Toyota LC80	BBT004
Toyota LC105	BBT005
Toyota LC100 IFS	BBT006
Toyota Prado 90	BBT007
Toyota Prado 120	BBT008
Nissan Patrol GU 1998-2004	BBT009
Nissan Patrol GQ	BBT010
Nissan Patrol GU S4 2005+	BBT011
Nissan Navara D40 Dual Cab	BBT012
Nissan Navara D40 Single Cab / Extra Cab	BBT012E
Nissan Navara D22	BBT013
Ford Ranger 2007-	BBT014
Ford Courier/Mazda Bravo 1996-2007 (with flares)	BBT015
Mitsubishi Triton ML 2006-	BBT016
Mitsubishi Triton MK 1996-2006	BBT017
Holden Rodeo RA7 / Isuzu D-Max 2007-	BBT020
Mazda BT50 2007-	BBT024
Toyota LC200	BBT025
Holden Colorado 2008-	BBT027

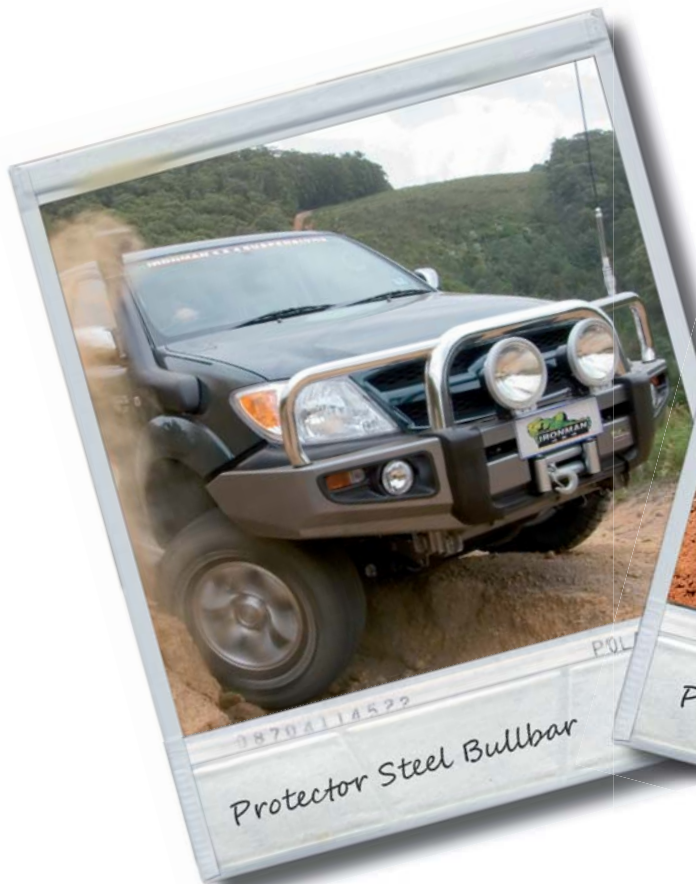

RECOVERY EQUIPMENT



ELECTRIC WINCH

Product	Part Number
Monster Winch 9500lbs 12v Electric	WWW9500
Monster Winch 12000lbs 12v Electric	WWW12000

HAND WINCH

Product	Part Number
Hand Winch 1600kg, Incl Carrybag	IHANDWINCH001

KITS / STRAPS AND ACCESORIES

Product	Part Number
Outback Winch Recovery Kit	IRECOVERY
Snatch Recovery Kit	IRECOVERY SMALL
Towbar Recovery Hook 4.7T	IHOOK
Towbar Recovery Bow Shackle 4.7T	IHOOK BOW
Snatch Strap 8,000kg x 9m, Incl Carrybag	ISNATCH
Snatch Strap 11,000kg x 9m, Incl Carrybag	ISNATCH002
Winch Damper Blanket	WINCHBLANKET

LIFTING JACKS

Product	Part Number
High Lift Jack 48" Incl Cover	IHIGHLIFT001
Exhaust Maxi Jack 4.2T, Incl Carrybag	IEXJACK001

TYRE REPAIR

Product	Part Number
Flo-Max Air Compressor 12v, Incl Carrybag	ICOMPRESSOR001
Tyre Repair Kit (36pc)	ITYRE001
Tyre Repair Cord Refill (25pc)	ITYRE002

FIRST AID

Product	Part Number
First Aid Kit (32pc)	IFIRSTAID001





RECOVERY EQUIPMENT

RECOVERY EQUIPMENT

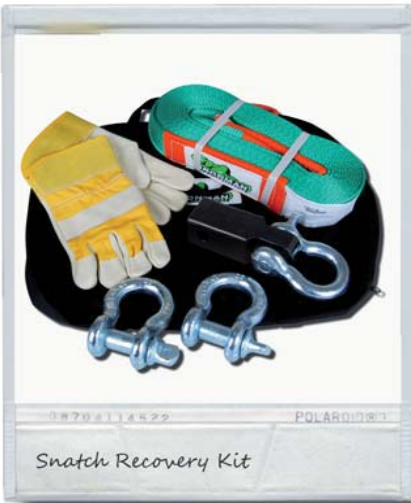

POWER MANAGEMENT



DUAL BATTERY KITS

Product	Part Number
Dual Battery Kit 140amp, Incl Monitor	DB001
Dual Battery Kit 275amp Incl Monitor & Override	DB002



140amp Dual Battery Kit

270amp Dual Battery Kit



DRIVING LIGHTS

Product	Part Number
Gamma 100W Halogen Driving Light 7" (H3) (Pair)	IGAMMA175
Vega 100W Halogen Driving Light 9" (H1) (Pair)	IVEGA220
Supernova 35W HID Driving Light 9" (H11, 6000k) (Pair)	IHID001
Luxloom Wiring Kit	ILOOM001

PORTABLE LED LIGHTING

Product	Part Number
Cordless Ultralight 12v / 240v Rechargeable	ITORCHLED001

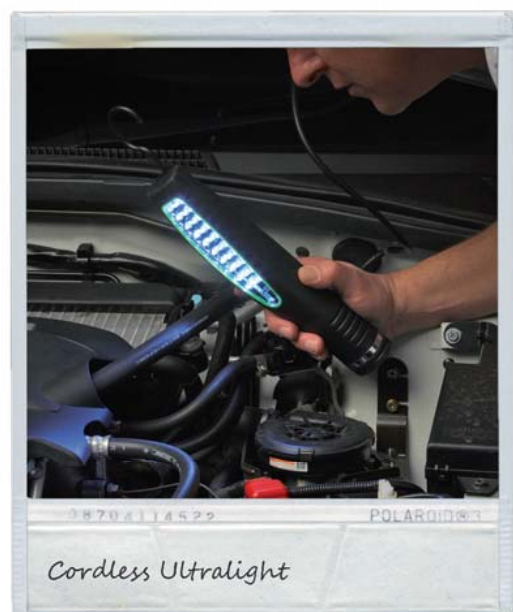
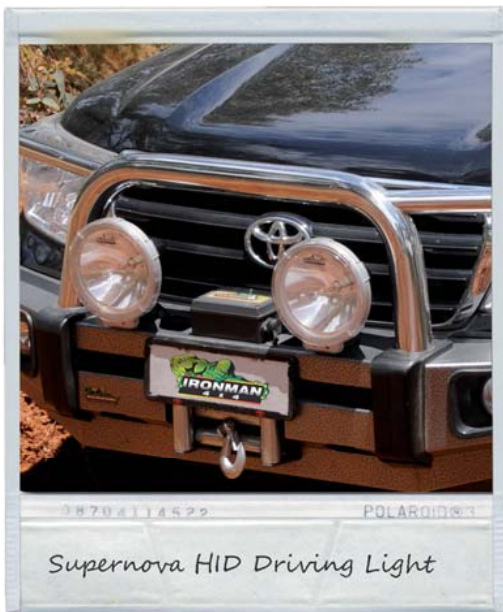
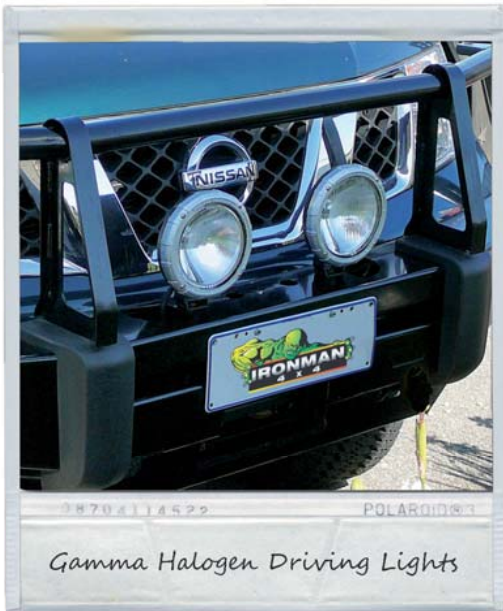

CANOPIES

ABS PLASTIC



THERMO-PLAS CANOPY

Product	Part Number
Toyota Hilux 2005- (A Deck) ¹	CANOPY001
Toyota Hilux 2005- (J Deck) ¹	CANOPY002
Nissan Navara D40 ²	CANOPY003
Ford Ranger / Mazda BT50 2007- ²	CANOPY004
Mitsubishi Triton ML 2006- ¹	CANOPY005
Holden Rodeo RA, RA7 / Colorado / Isuzu D-Max 2007- ¹	CANOPY006

ACCESSORIES

Product	Part Number
Lift Up Window (Left Side) (Round Profile)	CANOPY S1 LIFTUP ¹
Lift Up Window (Left Side) (Square Profile)	CANOPY S2 LIFTUP ²
Aluminium Roof Cross Bars	CROSS BAR

NOTE: All Canopies - 4X4 & 4X2 Dual Cab Models Only.

¹ Round Profile Canopy.

² Square Profile Canopy.





UTE LINERS

UTE LINERS

DUAL CAB UTE LINERS

Product	Part Number
Toyota Hilux 2005- (A Deck)	LINER001
Toyota Hilux 2005- (J Deck)	LINER001-J
Nissan Navara D40	LINER002
Ford Ranger / Mazda BT50 2007-	LINER003
Mitsubishi Triton ML 2006-	LINER004
Holden Rodeo RA, RA7 / Colorado / Isuzu D-Max 2007-	LINER005

ACCESSORIES

Product	Part Number
Superlock Tiedown Kit	SUPERLOCK*

** Superlock Kit is supplied with every Ironman Ute Liner.
Also fits most OE Ute Liners.*

NOTE: All Ute Liners - 4X4 & 4X2 Dual Cab Models Only.

NOTE: Liners are not compatible with Hardtop Lids.



STEPS AND BARS



STEEL SIDE STEPS

Product	Part Number
Holden Rodeo RA 2002-	SS001
Mitsubishi Triton ML 2006-	SS004
Toyota Hilux 2005-	SS006
Nissan Navara D40	SS007
Ford Ranger 2007-	SS008
Mazda BT50	SS009

ALLOY SIDE STEPS

Product	Part Number
Holden Rodeo RA 2002-	SSA001
Mitsubishi Triton ML 2006-	SSA004
Toyota Hilux 2005-	SSA006
Nissan Navara D40	SSA007
Ford Ranger 2007-	SSA008
Mazda BT50	SSA009

REAR STEP TOWBARS

Product	Part Number
Toyota Hilux 2005-	TRST-A
Nissan Navara D40	TRST-B
Mitsubishi Triton ML 2006-	TRST-C
Holden Rodeo RA, RA7 / Colorado / Isuzu D-Max 2007-	TRST-D
Ford Ranger / Mazda BT50 2007	TRST-E





UTE BOXES

Product

**Part
Number**

Lockable Utility Box (140L)
Lockable Utility Box (200L)

UTEBOX001
UTEBOX002









FORTEC GMBH · OSTERBROOKSWEG 71 · D-22869 SCHENEFELD
FON: +49 (0)40-839 233-0 · FAX: +49 (0)40-839 233-72
MAIL@FORTEC.DE · WWW.AUTOMOBILES.DE · WWW.FORTEC.DE



Händler: